

A

PISTON PUMPS

	Model No.	Maximum operating pressure MPa {kgf/cm ² }	Theoretical discharge rate cm ³ /rev										Permissible rotational speed min ⁻¹	Page		
			0	1	5	10	50	100	500	1000						
V series	V8	7 {70}	8.0											500 to 1800	A-8	
	V15	21 {210}	14.8													
	V15 (Type Y)	7 {70}														
	V23	25 {250}	23.0													
	V38		37.7													
	V50	21 {210}	51.6													
	V70		69.8													
VZ series	VZ50	28 {280}	50.2											500 to 1800	A-44	
	VZ63		63.0													
	VZ80		79.6													
	VZ100		104.6													
	VZ130	21 {210}	135.9													
Twin pump series	VD×-8A	Shaft side V8	7 {70}	8											600 to 1800	A-65
		End side DS10P	7 {70}	2.77 to 12.3												
	VD×-15A	Shaft side V15	21 {210}	14.8												
		End side DS10P	7 {70}	2.77 to 12.3												
	VD×-38A	Shaft side V38	21 {210}	37.7												
		End side DS10P	7 {70}	2.77 to 12.3												
V1515A	Shaft side V15	21 {210}	14.8											500 to 1800	A-67	
	End side V15	14 {140}	14.8													

Control method

Control method		JIS graphic symbols for hydraulic system	Characteristics	Features/Application
Control	Code			
Pressure compensator control	A			<ul style="list-style-type: none"> When the discharge pressure approaches the preset full-cutoff pressure, the discharge rate automatically decreases to the level required to maintain the preset pressure. The full-cutoff pressure and discharge rate can be manually adjusted.
Remote pressure compensator control	A-RC			<ul style="list-style-type: none"> The full-cutoff pressure can be adjusted through remote operation of the remote control relief valve. The discharge rate can be manually adjusted.
Combination control (pressure feedback method) (*1)	CH			<ul style="list-style-type: none"> This control method achieves both low-pressure high-flow-rate control and high-pressure low-flow-rate control with a single pump and this helps reduce power consumption and suppress oil temperature rise. When the discharge pressure approaches the preset pressure PL, the discharge rate automatically decreases to QL. The discharge rate automatically changes according to increase/decrease of the actuator pressure and this enables switching of the feedrate. The feedrate switches to a low value at the start of machining.
Combination control with remote pressure compensator (pressure feedback method)	CH-RC			<ul style="list-style-type: none"> The high pressure can be remotely adjusted using the remote control relief valve.
Combination control (solenoid operated method) (*1)	CJ			<ul style="list-style-type: none"> The control mode can be switched between high-pressure low-flow-rate control and low-pressure high-flow-rate control by turning the solenoid on and off and this enables switching between high and low actuator feedrates. Machining can be started after switching to the low feedrate.
				<ul style="list-style-type: none"> Two types of variable pump characteristics (high-pressure high-flow-rate and low-pressure low-flow-rate) can be selected by turning the solenoid on and off.
Combination control with remote pressure compensator (solenoid operated method)	CJ-RC			<ul style="list-style-type: none"> The high pressure can be remotely adjusted using the remote control relief valve.

Control method

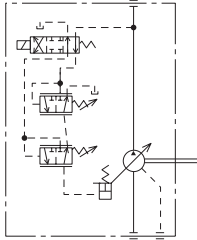
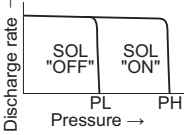
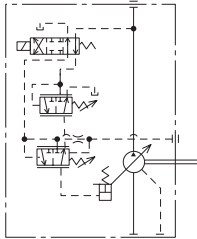
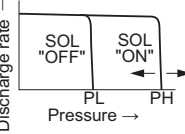
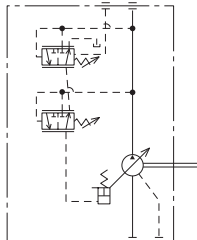
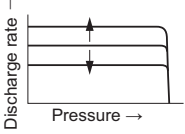
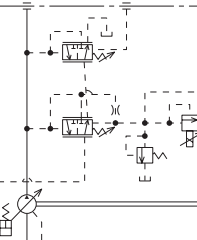
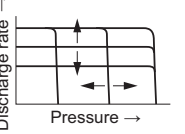
Control method		JIS graphic symbols for hydraulic system	Characteristics	Features/Application
Control	Code			
Dual pressure control (*1)	D			<ul style="list-style-type: none"> Two different full-cutoff pressures (high/low) can be selected by turning the solenoid on and off. Two different pressures can be set while maintaining a constant actuator feedrate. The full-cutoff pressure and discharge rate can be manually adjusted.
Dual pressure control with remote pressure compensator	D-RC			<ul style="list-style-type: none"> The high pressure can be remotely adjusted using the remote control relief valve.
Power match control	SA			<ul style="list-style-type: none"> Combining this control method with a proportional control valve achieves energy efficient control of a pump, where the minimum pressure and flow rate to operate the actuator are supplied.
	SAJS			<ul style="list-style-type: none"> This control method enables control of the full-cutoff pressure in proportion to the current input to the electromagnetic proportional relief valve, in addition to the functions provided with the SA type control.

Note: *1 Some models are available with a control function to set the pump in a feathering status (status where low pressure is cut off) by operating a solenoid valve. This function is effective for saving energy while the machine is at a stop. Please consult us about detailed information.

Operating principle of variable displacement piston pumps

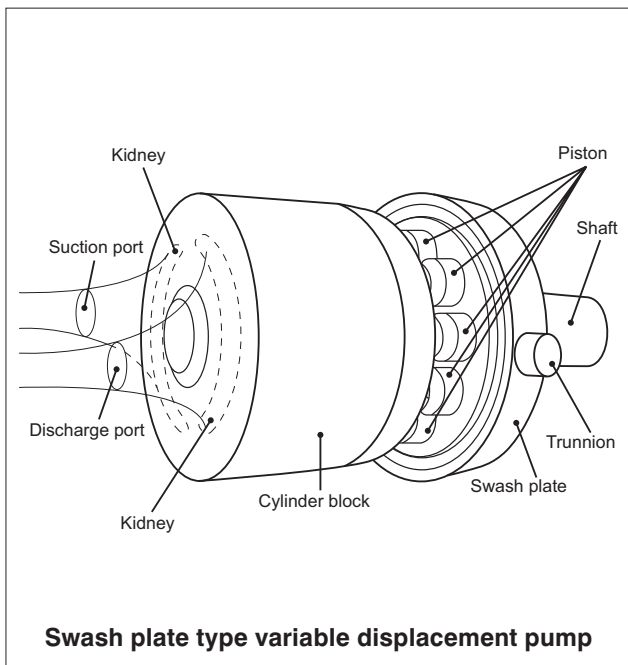

Swash plate type variable displacement pump

- When the shaft is rotated by an electric motor or an engine, the cylinder block is rotated on the valve plate surface while maintaining a slight clearance, and the pistons contained in the cylinder block reciprocate following the swash plate. The volume of the oil chamber varies with the reciprocating movement of the pistons, sucking in and discharging oil.
- During the suction process, an amount of oil corresponding to the piston stroke is drawn through the suction port of the end-cap, passing through the valve plate port of the cylinder block, while the piston moves from the bottom dead point to the top dead point. During the discharge process, oil is forced out through the discharge port of the end-cap, passing through the valve plate port, while the piston moves from the top dead point to the bottom dead point.
- One rotation of the cylinder block performs one suctioning and discharging cycle, and continuous pumping operation can be achieved by rotating the shaft connected to the cylinder block.

Models

	Model No.	Piping direction	Control method										
			A	A-RC	CH	CH-RC	CJ	CJ-RC	D	D-RC	SA	SAJS	
V series	V8	Side port	R	-	-	-	-	-	-	-	-	-	
	V15	Side port	R (L)	R (L)	R	R	R	R	R	R	R (L)	-	
		Axial port	R (L)	R (L)	-	-	-	-	-	-	-	R (L)	-
	V23	Side port	R (L)	R (L)	R	R	R	R	R	R	R	R (L)	R
		Axial port	R (L)	R (L)	-	-	-	-	-	-	-	R (L)	-
	V38	Side port	R (L)	R (L)	R	R	R	R	R	R	R	R (L)	R (L)
		Axial port	R (L)	R (L)	-	-	-	-	-	-	-	R (L)	-
V50	Side port	R (L)	R (L)	-	-	-	-	-	-	-	R (L)	R (L)	
V70	Side port	R (L)	R (L)	R	-	-	-	-	-	-	R (L)	R	
VZ series	VZ50	Side port	R	R	R	-	R	-	-	-	-	-	
	VZ63	Side port	R	R	R	-	R	-	-	-	-	-	
	VZ80	Side port	R	R	R	-	R	-	-	-	-	-	
	VZ100	Side port	R	R	R	-	R	-	-	-	-	-	
	VZ130	Side port	R	R	-	-	-	-	-	-	-	-	

Note: R in the table indicates clockwise rotation of the shaft and L indicates counterclockwise rotation, when viewed from the shaft end.

Models compatible with fire-resistant hydraulic oil

Model No.	Hydraulic oil	Control method									
		A	A-RC	CH	CH-RC	CJ	CJ-RC	D	D-RC	SA	SAJS
V8	Water-glycol hydraulic fluid (W)	-	-	-	-	-	-	-	-	-	-
	Phosphate ester hydraulic fluid (F)	-	-	-	-	-	-	-	-	-	-
V15	Water-glycol hydraulic fluid (W)	✓	✓	✓	✓	✓	✓	✓	✓	✓	-
	Phosphate ester hydraulic fluid (F)	✓	✓	✓	✓	✓	✓	✓	✓	✓	-
V23	Water-glycol hydraulic fluid (W)	✓	✓	✓	✓	✓	✓	✓	✓	✓	✓
	Phosphate ester hydraulic fluid (F)	✓	✓	✓	✓	✓	✓	✓	✓	✓	-
V38	Water-glycol hydraulic fluid (W)	✓	✓	✓	✓	✓	✓	✓	✓	✓	✓
	Phosphate ester hydraulic fluid (F)	✓	✓	✓	✓	✓	✓	✓	✓	✓	-
V50	Water-glycol hydraulic fluid (W)	✓	✓	-	-	-	-	-	-	✓	✓
	Phosphate ester hydraulic fluid (F)	✓	✓	-	-	-	-	-	-	✓	-
V70	Water-glycol hydraulic fluid (W)	✓	✓	✓	-	-	-	-	-	✓	✓
	Phosphate ester hydraulic fluid (F)	✓	✓	✓	-	-	-	-	-	✓	-

Note: There are no models for flame-resistant hydraulic oil in the VZ series.

● Conditions of use

When using flame-resistant hydraulic oil, use the product under the following conditions.

Hydraulic oil	Rotational Speed min ⁻¹	Operating pressure MPa {kgf/cm ² }		Oil temperature	Suction filter Filter	Suction pressure kPa {mmHg}
		Maximum	Rated			
Water-glycol hydraulic fluid (W)	800 to 1200	17.5 {175}	14 {140}	45°C maximum	100 meshes per inch	No lower than -10 {-75}
	1200 to 1800	14 {140}	14 {140}			
Phosphate ester hydraulic fluid (F)	800 to 1800	21 {210}	14 {140}	50°C maximum	100 meshes per inch	No lower than -10 {-75}

Handling

● Hydraulic oil

- For pressures of up to 7 MPa {70 kgf/cm²}, use a general-purpose hydraulic oil (R&O) or wear-resistant hydraulic oil equivalent to ISO VG32 to 68.
- For pressures higher than 7 MPa {70 kgf/cm²} use wear-resistant hydraulic oil equivalent to ISO VG32 to 68.
- Operate the unit in an environment where both the following conditions are satisfied: viscosity range from 15 to 400 mm²/s {cSt} and oil temperature from 0 to 60°C.
- Contamination of the hydraulic fluid causes pump trouble and reduces the service life, so pay due attention to controlling contamination and ensure that it goes no higher than NAS contamination class 9.

● Installation and alignment

- Ensure that the eccentricity of the drive shaft and pump shaft is no greater than 0.05 mm (TIR), and run the pump with no force acting perpendicularly on the pump shaft.
Misalignment between the shaft centers will cause damage to bearings and oil seals, generate noise and vibration, and lead to pump accidents.
- Avoid crosswise drive using a belt, chain or gears (it will cause noise generation or damage to the bearings).

● Filters

- Use a suction filter with 150 meshes per inch at the inlet side.
- In the return line to the tank at the discharge side, use a line filter with a filtration accuracy of 25 μm or better.
For discharge pressures of 14 MPa {140 kgf/cm²} and greater, use a line filter with a filtration accuracy of 10 μm.

Handling

● Piping

- When using steel pipes for piping, take care not to force the pump off center.
Forcing the pump off center with pipes may cause abnormal noise.

Model No.	V series				
	V8	V15, V23	V15 (Type Y)	V38	V50, 70
Suction port	G $\frac{3}{4}$ Bonded seal	G1 O-ring boss	SHA15/SSA20 (JIS B 2291)	G1 $\frac{1}{4}$ O-ring boss	Size 1 $\frac{1}{2}$ split flange boss (SAE J518 STANDARD) (PRESSURE SERIES)
Discharge port	G $\frac{3}{4}$ Bonded seal	G1 O-ring boss	Rc $\frac{3}{8}$	G1 $\frac{1}{4}$ O-ring boss	Size 1 $\frac{1}{2}$ split flange boss (SAE J518 STANDARD) (PRESSURE SERIES)
O-ring used	-	JIS B 2401 1BP29	-	JIS B 2401 1BP38	-

Model No.	VZ series		
	VZ50, VZ63	VZ80, VZ100	VZ130
Suction port	Size 1 $\frac{1}{2}$ split flange boss (SAE J518 STANDARD) (PRESSURE SERIES)	Size 2 split flange boss (SAE J518 STANDARD) (PRESSURE SERIES)	Size 2 $\frac{1}{2}$ split flange boss (SAE J518 STANDARD) (PRESSURE SERIES)
Discharge port	Size 1 split flange boss (SAE J518 STANDARD) (PRESSURE SERIES)	Size 1 $\frac{1}{2}$ split flange boss (SAE J518 STANDARD) (PRESSURE SERIES)	Size 1 $\frac{1}{2}$ split flange boss (SAE J518 STANDARD) (PRESSURE SERIES)

- Bonded seal model (manufacturer: IHARA SCIENCE CORPORATION)

Nominal model	Nominal designation of applicable thread
KP-C-05	G $\frac{3}{4}$

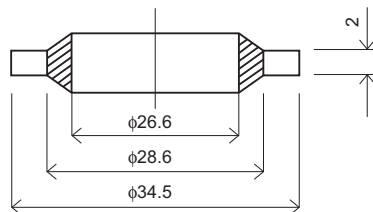

● Drain piping

- Isolate drain piping from other returning lines do not merge it with them and arrange it such that the pressure inside the pump case can be maintained at no greater than 0.035 MPa {0.35 kgf/cm²} for the V series and 0.1 MPa {1 kgf/cm²} for the VZ series.
- Merge the return line of the drain piping lower than the tank oil level and as far as possible from the suction line.

Model No.	V series			VZ series	
	V8, V15, V23	V38	V50, V70	VZ50	VZ63, VZ80 VZ100, VZ130
Size of pipe joint	Rc $\frac{3}{8}$ I.D. ϕ 8.5 minimum	Rc $\frac{1}{2}$ I.D. ϕ 12 minimum	Rc $\frac{3}{4}$ I.D. ϕ 16 minimum	Rc $\frac{1}{2}$ I.D. ϕ 2 minimum	Rc $\frac{3}{4}$ I.D. ϕ 16 minimum
Pipe I.D.	ϕ 12 minimum	ϕ 15 minimum	ϕ 19 minimum	ϕ 15 minimum	ϕ 19 minimum
Drain pipe length	1 m maximum	1 m maximum	1 m maximum	1 m maximum	1 m maximum

● At start

- Fill the pump case with hydraulic fluid through the filler port before starting the pump. Use the same hydraulic fluid as for the hydraulic circuit.

Model No.	V series						VZ series				
	V8	V15	V23	V38	V50	V70	VZ50	VZ63	VZ80	VZ100	VZ130
Pump case filling volume cm ³	250	500	500	900	2000	2000	1000	1400	1500	2000	2500

- After checking that all hydraulic circuits and electrical circuits are ready for operation, set the hydraulic circuit at the load side in the no-load status or connect an unloading circuit before starting the pump.

Handling

● At start

- Check that the pump rotates in the direction of the arrow showing the direction of rotation.
- When the pump is driven for the first time, turn the power switch to the motor on and off a few times to let the air out of the piping and then run it continuously at full speed. Noise may be observed until the air has been completely removed but this is not abnormal.

● Suction pressure

- Maintain the suction pressure no lower than -16.7 kPa $\{-125 \text{ mmHg}\}$.
- High suction pressures will generate cavitation and cause damage to the parts, noise, and vibration, resulting in a shorter pump service life.

V series Piston Pump



Features

- **Low noise**
 - Low noise operation over the entire pressure range has been realized in each series.
- **High efficiency**
 - Fluid temperature rise can be reduced due to the smaller power loss. This means that the tank can be designed in a small size.
- **High reliability**
 - High responsiveness, high stability, and long life make it possible to increase the reliability of the main machine.

Nomenclature

● Pressure compensator control

※ - V ※※ A ※ ※ ※ - ※※ ※※
 1 2 3 4 5 12 15 16 17

● Combination control (pressure feedback method)

※ - V ※※ C ※ ※ R H X - ※※ ※※
 1 2 3 4 7 8 12 13 15 16 17

● Combination control (solenoid operated method)

※ - V ※※ C ※ ※ R J ※ X - ※※ ※※
 1 2 3 4 7 8 12 13 14 15 16 17

● Dual pressure control

※ - V ※※ D ※ ※ R ※ X - ※※ ※※
 1 2 3 4 9 10 12 14 15 16 17

● Power-match control

※ - V ※※ SA ※ ※ ※ ※ - ※※
 1 2 3 4 6 11 12 15 16

1 Applicable fluid code (Refer to Page A-5 for the applicable models and conditions of use)

No designation: Petroleum-based hydraulic fluid
 W: Water-glycol hydraulic fluid
 F: Phosphate ester hydraulic fluid

2 Model No.

V: V series piston pump

3 Pump capacity

8: 8.0 cm³/rev
 15: 14.8 cm³/rev
 23: 23.0 cm³/rev
 38: 37.7 cm³/rev
 50: 51.6 cm³/rev
 70: 69.8 cm³/rev

4 Control method I (Refer to Page A-4 for the applicable models)

A: Pressure compensator control
 C: Combination control
 D: Dual pressure control
 SA: Power-match control

5 6 Pressure adjustment range (See the pressure adjustment range table)

7 9 Low pressure adjustment range (See the pressure adjustment range table)

8 10 High pressure adjustment range (See the pressure adjustment range table)

11 FC valve differential pressure

A: 0.7 MPa { 7 kgf/cm² }
 B: 1.4 MPa { 14 kgf/cm² }
 C: 2.1 MPa { 21 kgf/cm² }

12 Direction of rotation, when viewed from the shaft end (Refer to Page A-4 for the applicable models)

R: Clockwise (rightward)
 L: Counterclockwise (leftward)

*The direction of rotation (rightward or leftward) cannot be changed.

13 Control method II

H: Pressure feedback method
 J: Solenoid operated method

14 Voltage code for the solenoid valve

A: AC 100 V (50/60 Hz), AC 110 V (60 Hz)
 B: AC 200 V (50/60 Hz), AC 220 V (60 Hz)
 N: DC 12 V
 P: DC 24 V

15 Piping direction (Refer to Page A-4 for the applicable models)

No designation: Axial port
 X: Side port

16 Design No. (The design No. is subject to change)*1

20: Pump model V8, V50
 95: Pump model V15, V38
 30: Pump model V23
 <When control method I is A, CH, or SA>
 35: Pump model V23
 <When control method I is CJ or D>
 60: Pump model V70

Control method III

17 No designation: Without remote control system
 RC: With remote control system

Note:*1 Refer to Page A-68 for information on forward/backward compatibility.

Refer to Page N-2 for hydraulic unit piston packs incorporating V series piston pumps, Page N-17 for NDJ series new DAIPACKs, Page N-22 for ND series Mini-packs, Page N-27 for ND series new DAIPACKs, and Page N-30 for the NT series SSS MARK-II.

Models and pressure adjustment range table

● Pressure compensator control (4 = A)

5 Pressure adjustment range

Code	Pressure adjustment range MPa {kgf/cm ² }	Without remote control system						With remote control system					
		V8	V15	V23	V38	V50	V70	V15	V23	V38	V50	V70	
1	0.8 to 7 {8 to 70}	✓	✓	✓	✓	-	-	-	-	-	-	-	-
1	1.5 to 7 {15 to 70}	-	-	-	-	✓	✓	-	-	-	-	-	-
2	1.5 to 14 {15 to 140}	-	✓	✓	✓	✓	✓	-	-	-	-	-	-
3	1.5 to 21 {15 to 210}	-	-	-	-	-	-	✓	-	-	-	-	-
3	2 to 21 {20 to 210}	-	-	-	-	-	-	-	-	-	✓	✓	-
3	3.5 to 21 {35 to 210}	-	✓	✓	✓	✓	✓	-	-	-	-	-	-
4	1.5 to 25 {15 to 250}	-	-	-	-	-	-	-	✓	✓	-	-	-
4	3.5 to 25 {35 to 250}	-	-	✓	✓	-	-	-	-	-	-	-	-

● Combination control [4 = C, 13 = H (self-regulation method) or 13 = J (solenoid operated method)]

7 Low pressure adjustment range

Code	Pressure adjustment range MPa {kgf/cm ² }	Pressure feedback method				Solenoid operated method		
		V15	V23	V38	V70	V15	V23	V38
1	1.5 to 7 {15 to 70}	-	-	-	✓	✓	✓	✓
1	2.5 to 7 {25 to 70}	✓	✓	✓	-	-	-	-
2	1.5 to 14 {15 to 140}	-	-	-	✓	✓	✓	✓
2	2.5 to 14 {25 to 140}	✓	✓	✓	-	-	-	-

8 High pressure adjustment range

Code	Pressure adjustment range MPa {kgf/cm ² }	Without remote control system						With remote control system						
		Pressure feedback method				Solenoid operated method		Pressure feedback method				Solenoid operated method		
		V15	V23	V38	V70	V15	V23	V38	V15	V23	V38	V15	V23	V38
1	1.5 to 7 {15 to 70}	-	-	-	✓	✓	✓	✓	-	-	-	-	-	-
1	2.5 to 7 {25 to 70}	✓	✓	✓	-	-	-	-	-	-	-	-	-	-
2	1.5 to 14 {15 to 140}	-	-	-	✓	✓	✓	✓	-	-	-	-	-	-
2	2.5 to 14 {25 to 140}	✓	✓	✓	-	-	-	-	-	-	-	-	-	-
3	2.0 to 21 {20 to 210}	-	-	-	-	-	-	-	-	-	-	✓	-	-
3	2.5 to 21 {25 to 210}	-	-	-	-	-	-	-	✓	-	-	✓	-	-
3	3.5 to 21 {35 to 210}	✓	✓	✓	✓	✓	✓	✓	-	-	-	-	-	-
4	2.0 to 25 {20 to 250}	-	-	-	-	-	-	-	-	-	-	-	✓	✓
4	2.5 to 25 {25 to 250}	-	-	-	-	-	-	-	-	✓	✓	-	-	-
4	3.5 to 25 {35 to 250}	-	✓	✓	-	-	✓	✓	-	-	-	-	-	-

● Dual pressure control (4 = D)

9 Low pressure adjustment range

Code	Pressure adjustment range MPa {kgf/cm ² }	V15	V23	V38
1	1.5 to 7 {15 to 70}	✓	✓	✓
2	1.5 to 14 {15 to 140}	✓	✓	✓

Note: If both low and high pressure adjustment ranges are the 1st pattern, the pressure adjustment range becomes 0.8 to 7 MPa {8 to 70 kgf/cm²}.

10 High pressure adjustment range

Code	Pressure adjustment range MPa {kgf/cm ² }	Without remote control system			With remote control system		
		V15	V23	V38	V15	V23	V38
1	1.5 to 7 {15 to 70}	✓	✓	✓	-	-	-
2	1.5 to 14 {15 to 140}	✓	✓	✓	-	-	-
3	2.5 to 21 {25 to 210}	-	-	-	✓	-	-
3	3.5 to 21 {35 to 210}	✓	✓	✓	-	-	-
4	2.5 to 25 {25 to 250}	-	-	-	-	✓	✓
4	3.5 to 25 {35 to 250}	-	✓	✓	-	-	-

● Power-match control (4 = SA)

6 Pressure adjustment range

Code	Pressure adjustment range MPa {kgf/cm ² }	V15	V23	V38	V50	V70
1	0.8 to 7 {8 to 70}	✓	✓	✓	-	-
1	1.5 to 7 {15 to 70}	-	-	-	✓	✓
2	1.5 to 14 {15 to 140}	✓	✓	✓	✓	✓
3	3.5 to 21 {35 to 210}	✓	✓	✓	✓	✓
4	3.5 to 25 {35 to 250}	-	✓	✓	-	-

Nomenclature

※ - V ※※ SAJS - ※ ※ X - ※※
 1 2 3 4 5 6 7 8

1 Applicable fluid code

No designation: Petroleum-based hydraulic fluid
 W: Water-glycol hydraulic fluid

2 Model No.

V: V series piston pump

3 Pump capacity

23: 23.0 cm³/rev
 38: 37.7 cm³/rev
 50: 51.6 cm³/rev
 70: 69.8 cm³/rev

4 Control method

SAJS: Power-match control

5 Pressure adjustment range

A: Up to 14 MPa {140 kgf/cm²}
 B: Up to 17.5 MPa {175 kgf/cm²}
 C: Up to 21 MPa {210 kgf/cm²}

* The minimum adjustment pressure varies depending on the model.

6 Direction of rotation, when viewed from the shaft end (Refer to Page A-4 for the applicable models)

R: Clockwise (rightward)
 L: Counterclockwise (leftward)

7 Piping direction

X: Side port

8 Design number

(The design number is subject to change)

30: Pump model V23
 95: Pump model V38
 20: Pump model V50
 60: Pump model V70

※ - V 15 A 1 R Y - 95
 1 2 3 4 5 6 7 8

1 Applicable fluid code

No designation: Petroleum-based hydraulic fluid
 W: Water-glycol hydraulic fluid
 F: Phosphate ester hydraulic fluid

2 Model No.

V: V series piston pump

3 Pump capacity

15: 14.8 cm³/rev

4 Control method

A: Pressure compensator control

5 Pressure adjustment range

1: 0.8 to 7 MPa {8 to 70 kgf/cm²}

6 Direction of rotation, when viewed from the shaft end

R: Clockwise (rightward)

Piping port

Y: Suction port: Flange
 Discharge port: Taper pipe threads

8 Design No. (The design No. is subject to change) *1

Note: *1 Refer to Page A-69 for information on forward/backward compatibility.

Specifications

Model No.	Theoretical discharge rate cm ³ /rev	Maximum operating pressure MPa {kgf/cm ² }	Permissible rotational speed min ⁻¹	Discharge rate adjustment range 1800 min ⁻¹ L/min		Mass (Control method A) kg	
				Axial port	Side port	Axial port	Side port
V8	8.0	7 { 70 }	500 to 1800	2 to 14.4	-	-	8.9
V15	14.8	21 {210}	500 to 1800	4.5 to 26.6	7.5 to 26.6	12.8	14.5
V15 (Type Y)	14.8	7 { 70 }	500 to 1800	4.5 to 26.6		13.5	
V23	23.0	25 {250}	500 to 1800	12 to 41.4	-	18.4	21.5
V38	37.7	25 {250}	500 to 1800	34 to 68	36.5 to 68	24.4	26
V50	51.6	21 {210}	500 to 1800	0 to 93	-	-	50
V70	69.8	21 {210}	500 to 1800	13 to 126	-	-	55

Note: JR-G (T) 02 and JRP-G02 are recommended for the remote control system's relief valve.

If the vent port is blocked, the pressure compensation structure does not work and the pump operates at a fixed pressure.

- Foot supports and piping flanges are not provided with the pump. Order them separately as required by referring to Pages S-2 and S-4.

Relationship between number of revolutions of the pressure adjusting screw and variation of discharge pressure

- The discharge pressure can be set to the desired value by turning the pressure adjusting screw of the PC valve.
 - Turning the adjusting screw clockwise increases the pressure.
 - Turning the adjusting screw counterclockwise decreases the pressure.

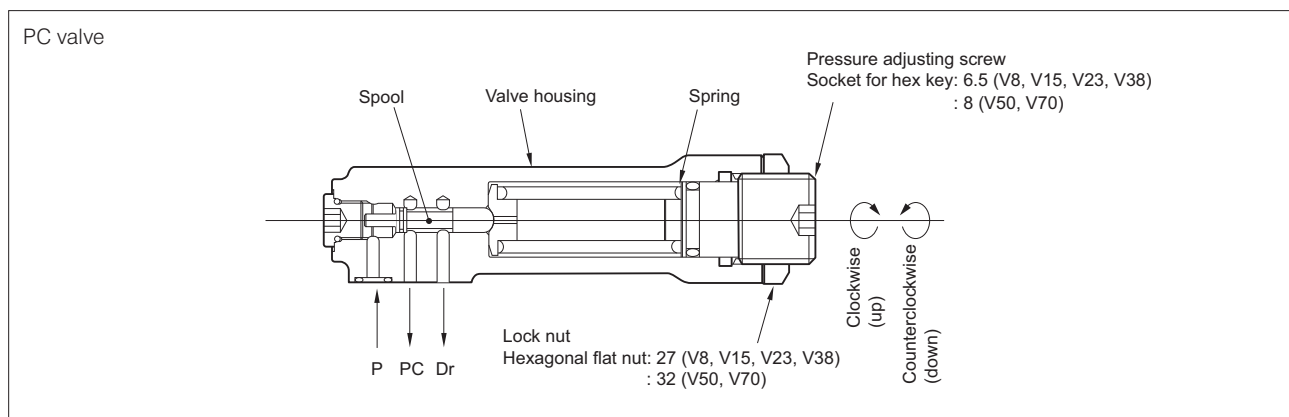
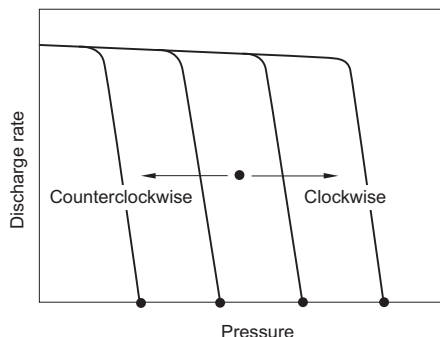

V8

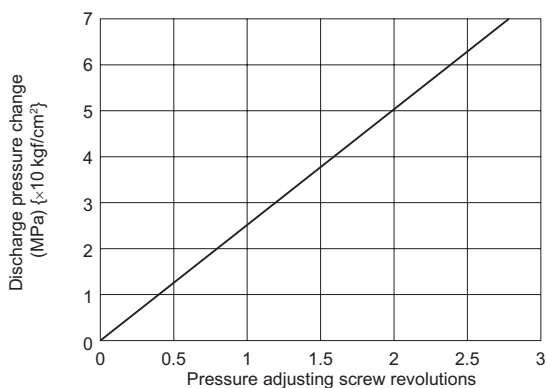

V15, 23, 38

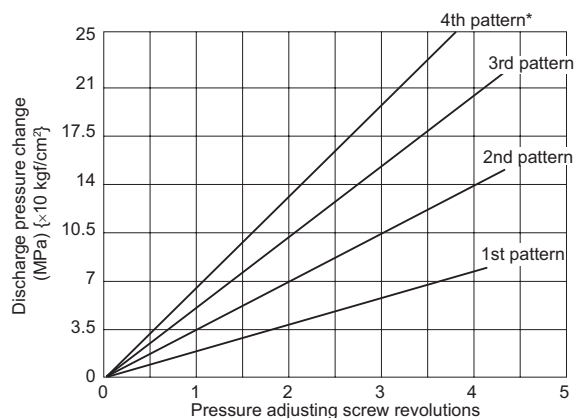

V50, 70

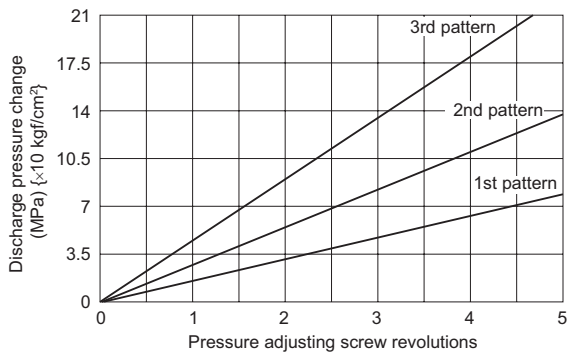

* The 4th pattern applies to V23 and V38.

- Excessive loosening of the pressure adjusting screw may cause oil to leak from the threaded section or parts to spring out. Do not loosen the screw beyond the pressure adjustment range.
- The 1st to 4th patterns correspond to the pressure adjustment range designation codes 1 to 4.

Relationship between the protruding length of the discharge rate adjusting screw and the discharge rate (4 = A, D, SA)

- The maximum discharge rate can be set to the desired value by turning the discharge rate adjusting screw at the end cap.
 - Turning the adjusting screw clockwise decreases the discharge rate.
 - Turning the adjusting screw counterclockwise increases the discharge rate.

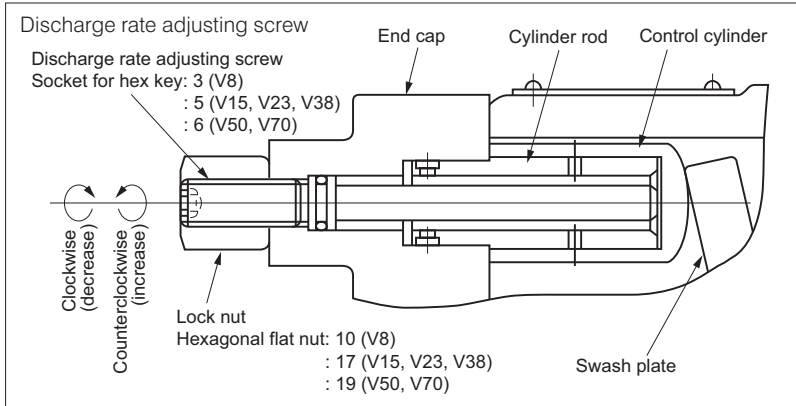
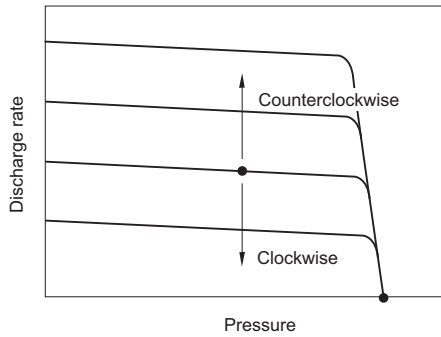

- The discharge rate can be roughly judged from the protruding length of the discharge rate adjusting screw (L).

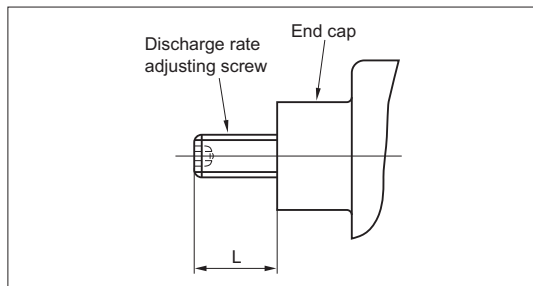

- Overtightening of the discharge rate adjusting screw may cause oil to leak from the threaded section. Do not tighten the screw beyond the adjustment range.

V8 side port

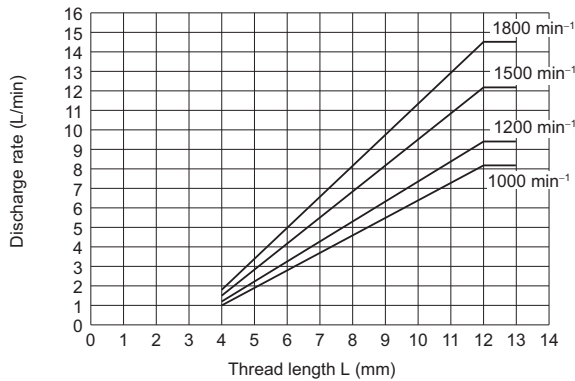

V15 axial port, V15 (type Y)

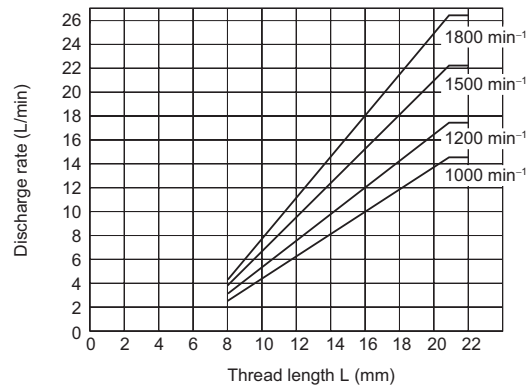

V15 side port

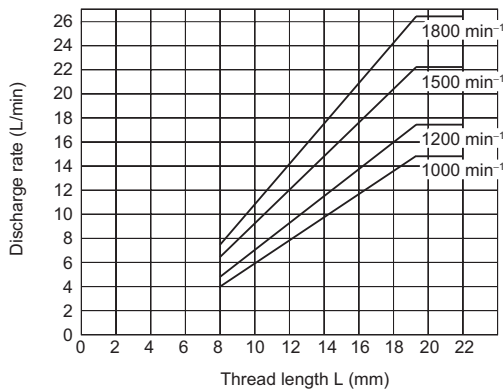

V23 axial port, side port

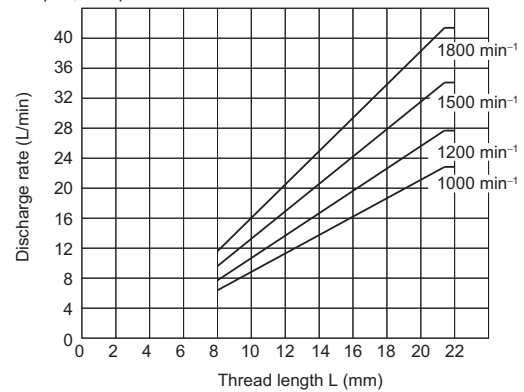

V38 axial port

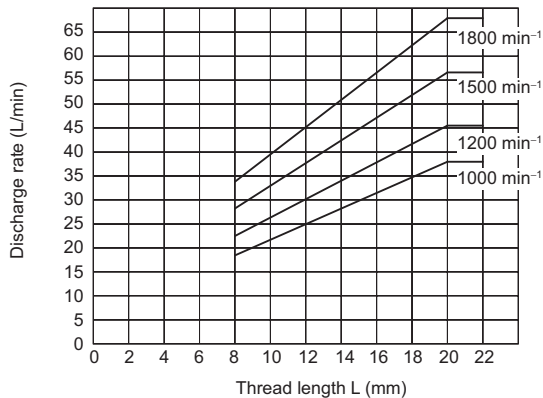

V38 side port

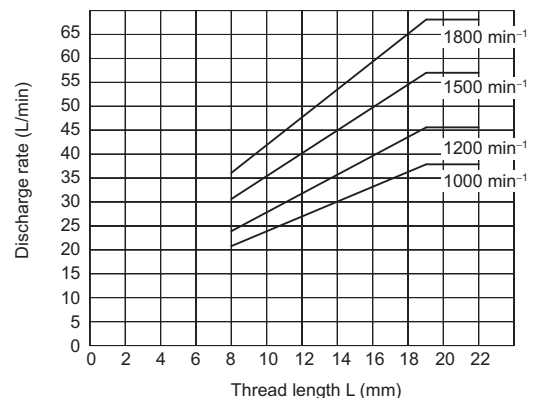

V50 side port

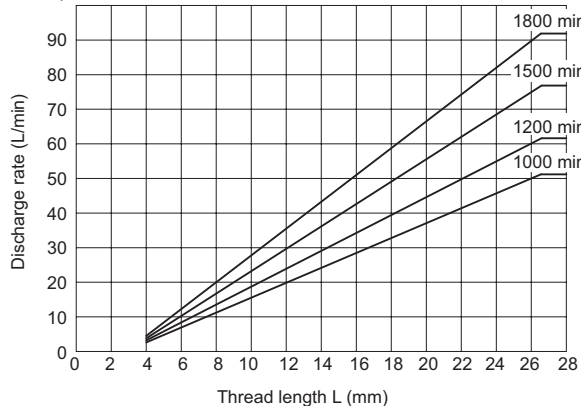

V70 side port

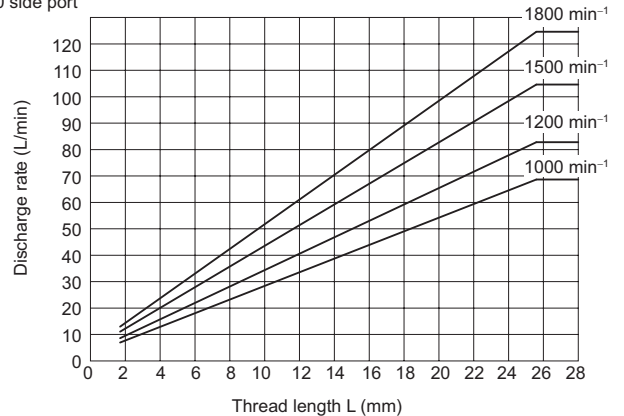

Relationship between the protruding length of the discharge rate adjusting screw and the discharge rate ($4 = C$)

● Discharge rate adjustment in combination control

The discharge rate for both the low quantity (QL) and high quantity (QH) ranges can be adjusted as follows:

- Turning the adjusting screw clockwise decreases the discharge rate.
- Turning the adjusting screw counterclockwise increases the discharge rate.

The discharge rate adjusting screws are provided with scales on the nameplates as shown below.

Pump model	Scale °	
	Low quantity adjusting screw	High quantity adjusting screw
V15C	0 to 7	5 to 15
V23C	0 to 9	8 to 17
V38C	0 to 9	9 to 18
V70C	0 to 9	6 to 18

(Scale graduation: 1°)

Note: The high quantity adjustment range may be restricted due to the setting for the low quantity range. See the graphs on Page A-15 for details.

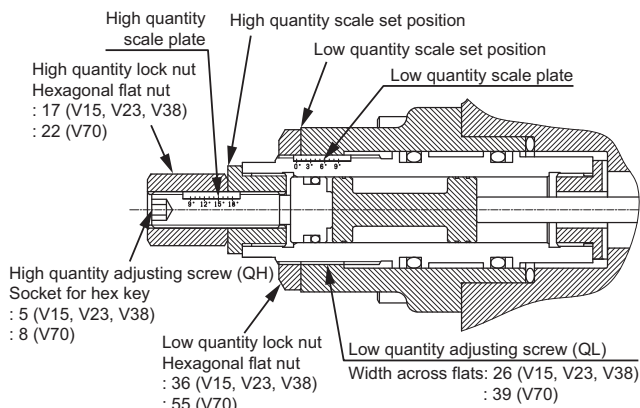

Adjust the discharge rate according to the relevant discharge rate adjustment graph by following the procedure below.

- (1) For the low quantity range, read the value for the desired discharge rate on the graph and turn the low quantity adjusting screw to set the scale position to the read value.
- (2) For the high quantity range, read the value for the desired discharge rate on the line corresponding to the value for the low quantity range on the graph and turn the high quantity adjusting screw to set the scale position to the read value.
- (3) When adjusting only the high quantity range, loosen the lock nut and adjust as described above.
- (4) When adjusting only the low quantity range, loosen the lock nut on the high quantity adjustment screw and adjust the setting for the low quantity range as described above while holding the high quantity adjusting screw in place with a hex key.

■ Example of adjustment

Example: When adjusting the discharge rate of V15C at 1500 min⁻¹ to 7 L/min for the low quantity range (QL) and 18 L/min for the high quantity range (QH)

- From the discharge rate adjustment graph for V15C at 1500 min⁻¹, first read the value for QL = 7 L/min, which is 4, and adjust the low quantity adjusting screw accordingly.
- Then, read the value for QH = 18 L/min on the line for 4 of QL, which is 7, and adjust the high quantity adjusting screw accordingly.

The setting values indicated above may change slightly depending on the conditions of use (fluid temperature, hydraulic fluid type, etc.)

For final fine adjustment, repeat the adjustment described above and achieve the setting appropriate for the actual application.

Factory settings

The discharge rate for the high quantity range is factory adjusted to the maximum discharge rate and the discharge rate for the low quantity range is factory adjusted as follows.

Pump model	Low quantity (QL) setting
V15C	Scale position: 3°
V23C	Scale position: 3°
V38C	Scale position: 2°
V70C	Scale position: 1.5°

Discharge rate adjustment graph for V15C in combination control

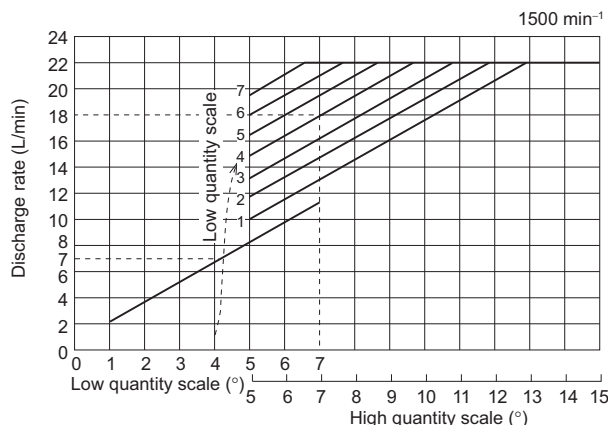

V15C combination control (1800 min⁻¹)

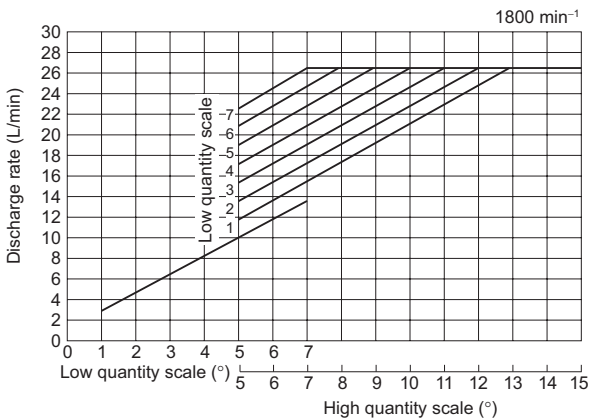

V15C combination control (1500 min⁻¹)

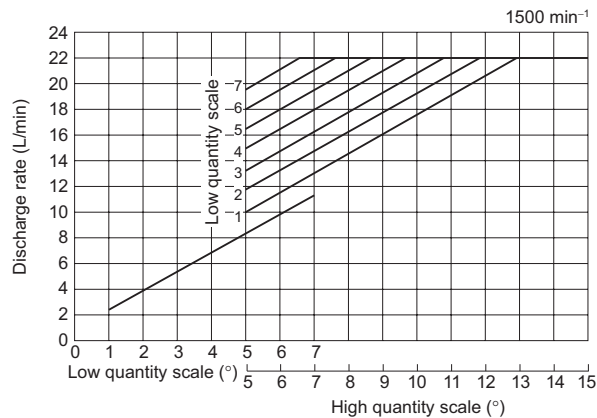

V23C combination control (1800 min⁻¹)

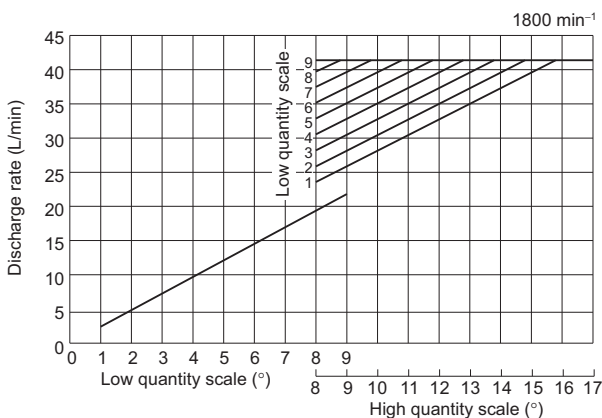

V23C combination control (1500 min⁻¹)

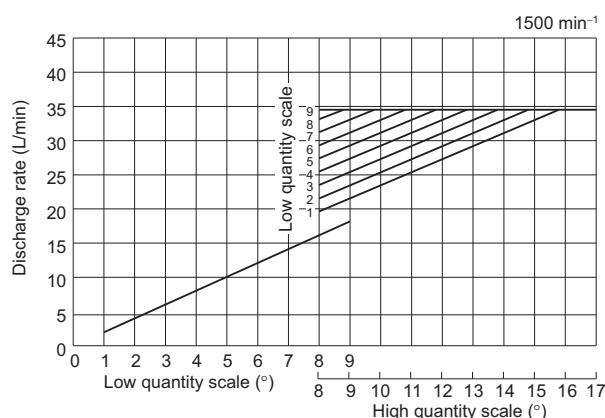

V38C combination control (1800 min⁻¹)

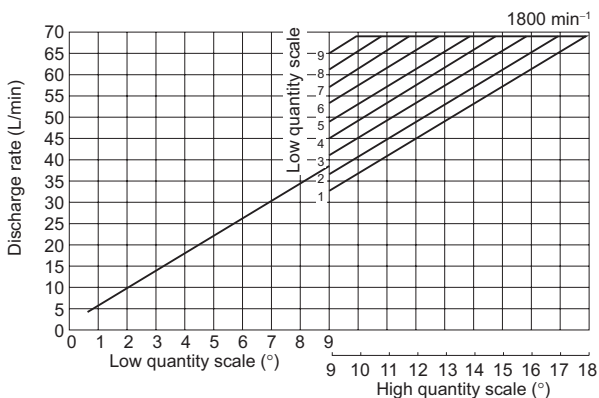

V38C combination control (1500 min⁻¹)

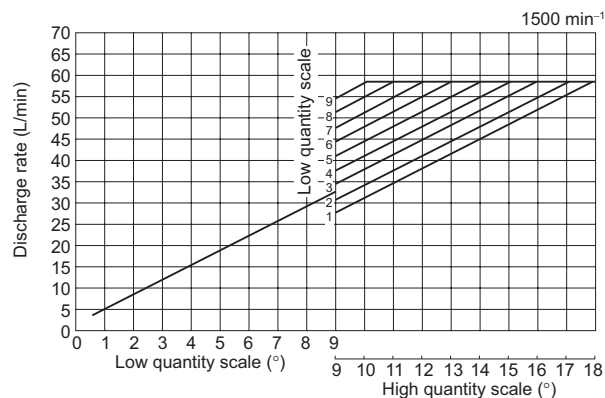

V70C combination control (1800 min⁻¹)

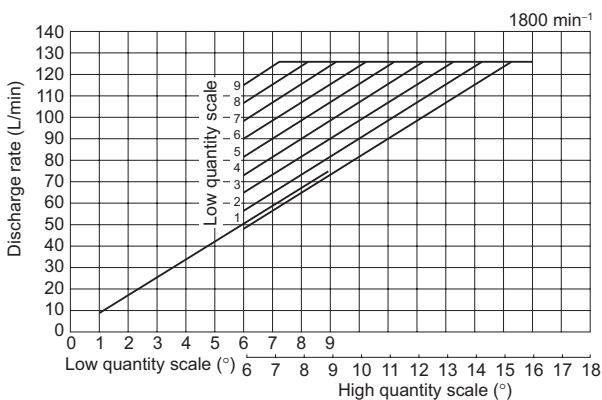

V70C combination control (1500 min⁻¹)

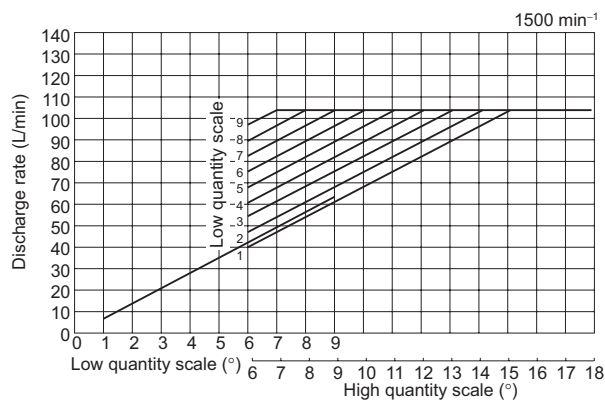

Pressure compensator characteristics

● Sharp cutoff characteristics

- The pressure gradient at cutoff is no greater than 0.5 MPa {5 kgf/cm²}
- Sharp and stable cutoff characteristics are achieved.

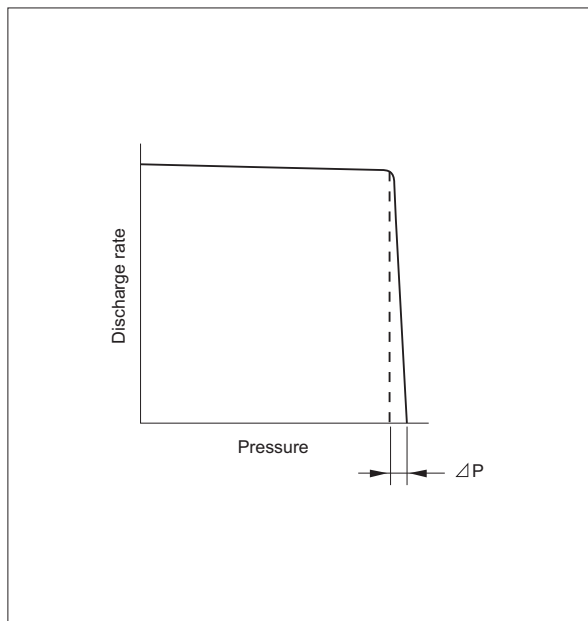

Response characteristics

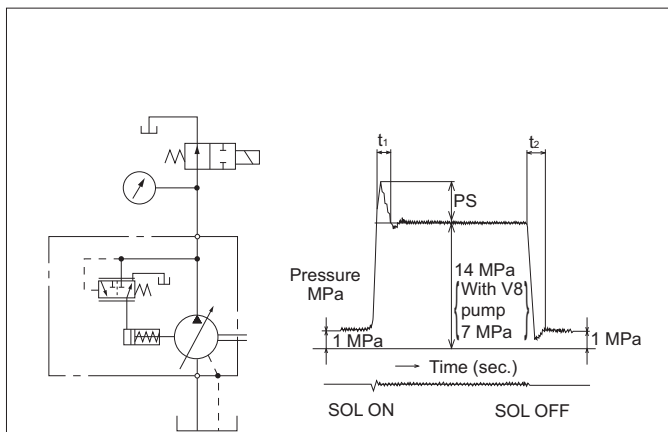

Model	Response time sec.		Surge pressure MPa
	t ₁	t ₂	Ps
V8	0.04 to 0.05	0.05 to 0.07	2.5 to 4
V15	0.04 to 0.05	0.05 to 0.07	2.5 to 4
V23	0.05 to 0.06	0.05 to 0.07	3.5 to 7
V38	0.05 to 0.09	0.05 to 0.07	5.5 to 9
V50	0.06 to 0.09	0.06 to 0.09	6 to 10
V70	0.06 to 0.09	0.06 to 0.09	6.5 to 10

Noise characteristics (JIS B 8350, measuring position: 1 m from pump front)

Input rotational speed	Fluid used	Oil temperature
1800 min ⁻¹ 1500 min ⁻¹	Equivalent to ISO VG32	50°C

- At full-cutoff at 1800 min⁻¹
- × At full-cutoff at 1500 min⁻¹

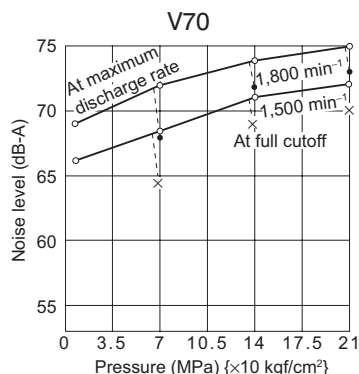
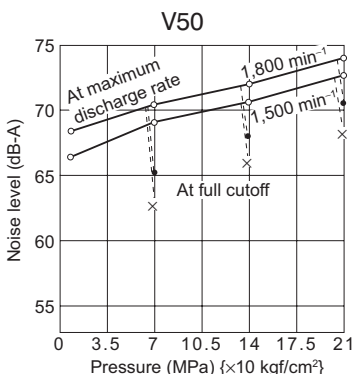
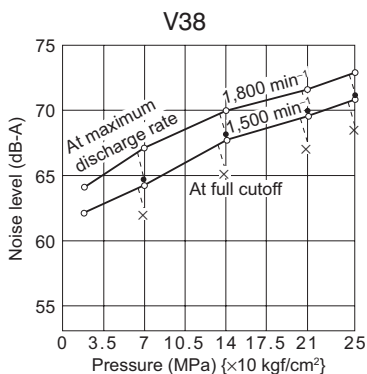
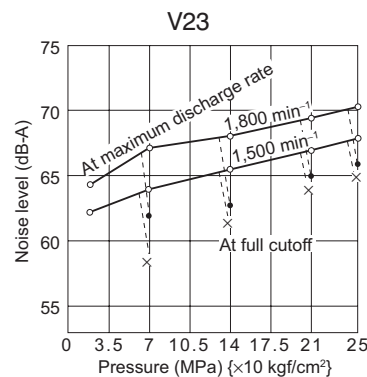
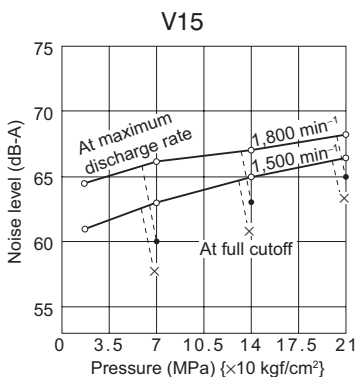
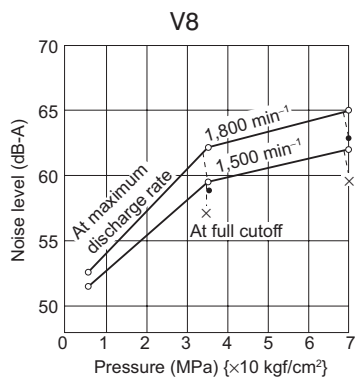

General performance

Discharge rate setting: maximum, Fluid used: ISO VG32, Fluid temperature: 50°C

1800 min⁻¹

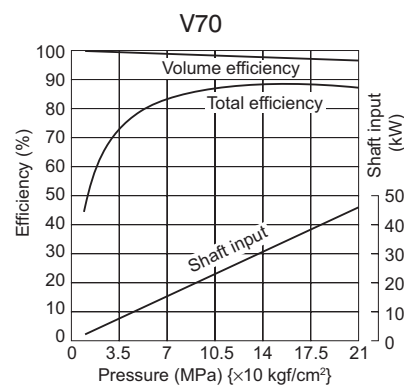
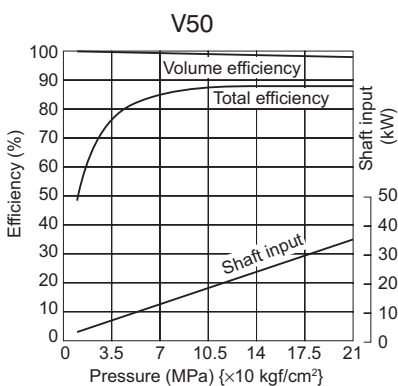
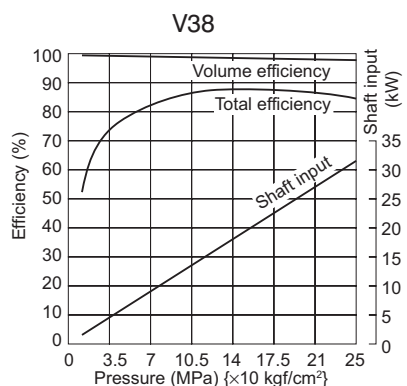
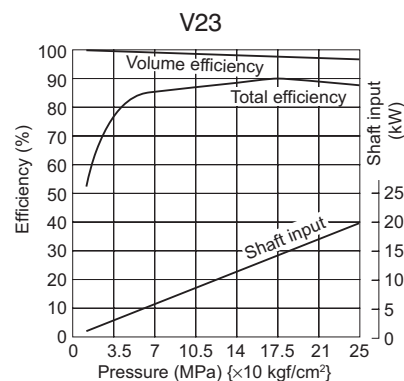
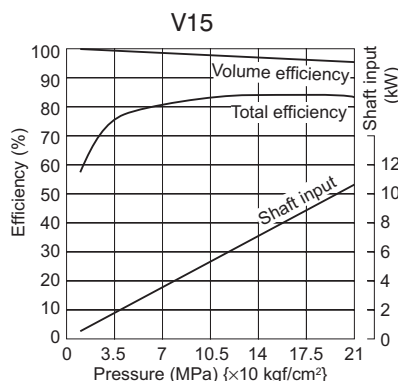
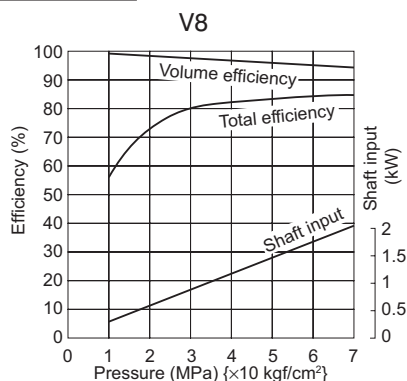

1500 min⁻¹

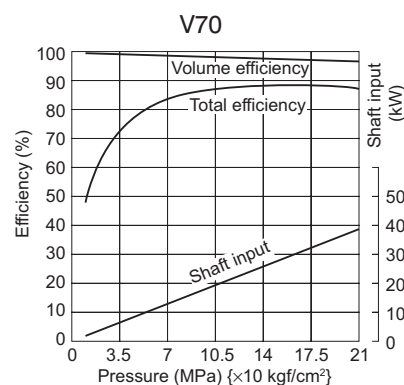
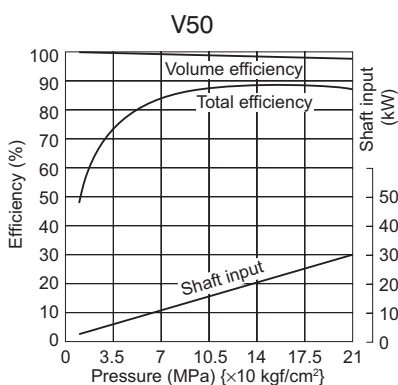
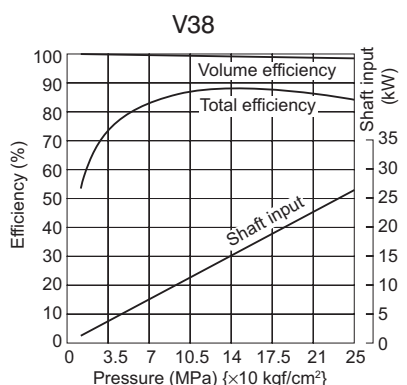
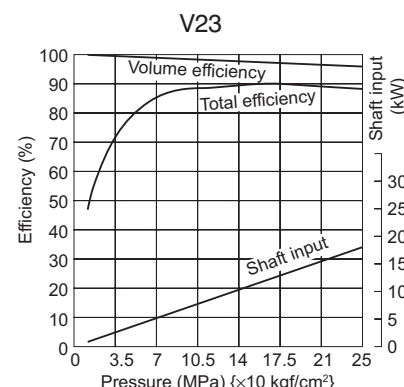
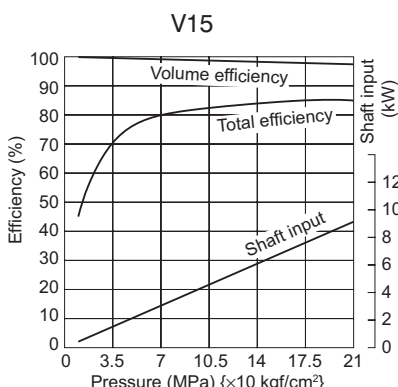
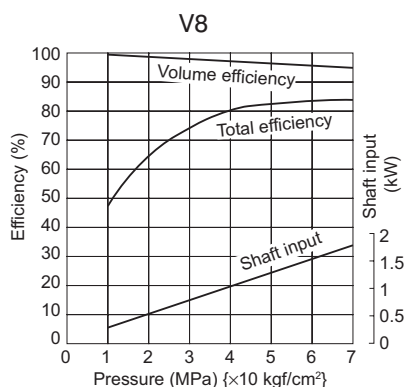

Note: The efficiency varies depending on the discharge rate setting. When selecting the motor capacity, refer to the shaft input characteristics on Page A-19.

Shaft input characteristics at full cutoff

Common to 1800 min⁻¹ and 1500 min⁻¹ Fluid used: ISO VG32, Fluid Temperature: 50°C

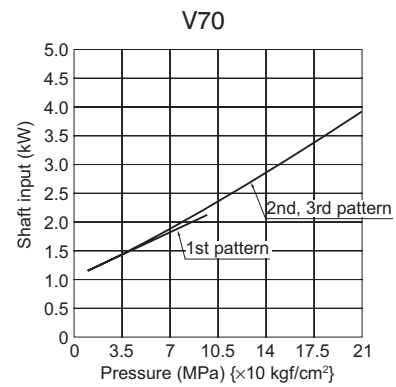
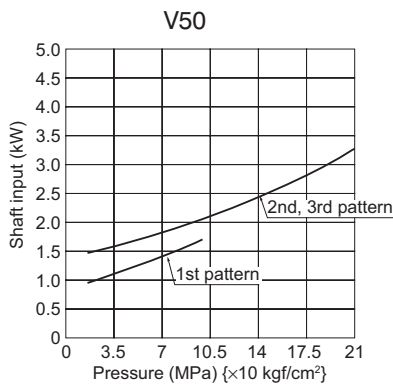
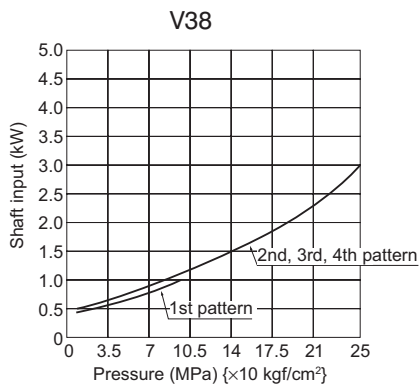
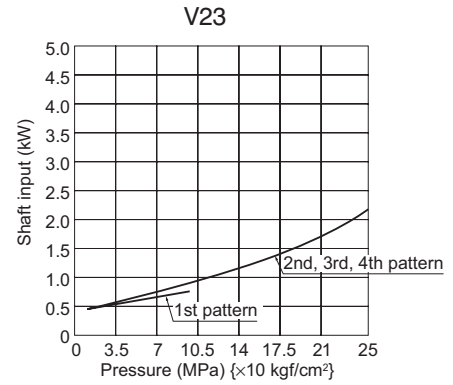
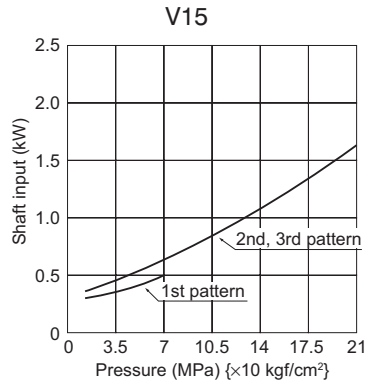
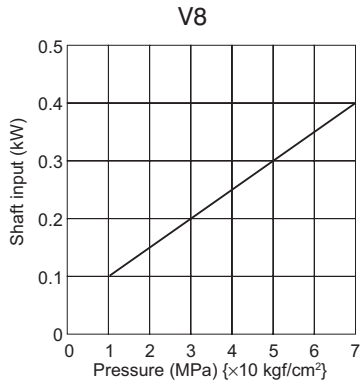

Shaft input characteristics

Common to 1800 min⁻¹ and 1500 min⁻¹ Fluid used: ISO VG32, Fluid Temperature: 50°C

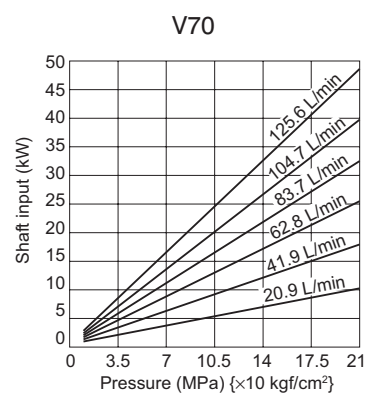
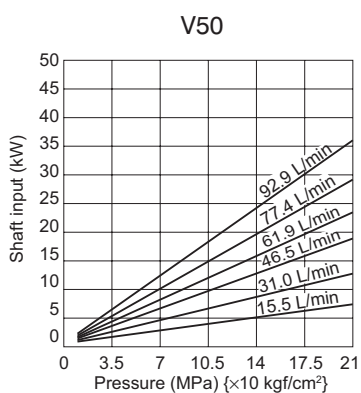
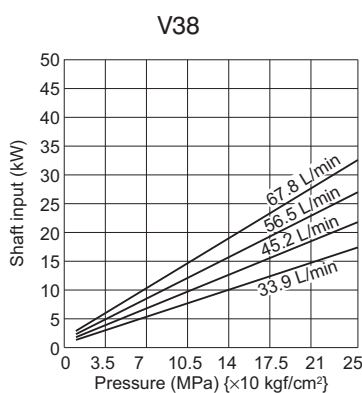
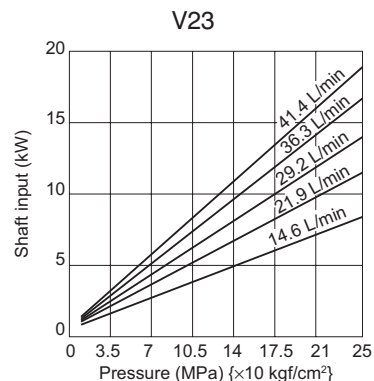
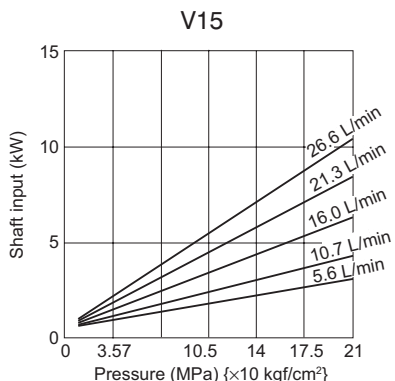
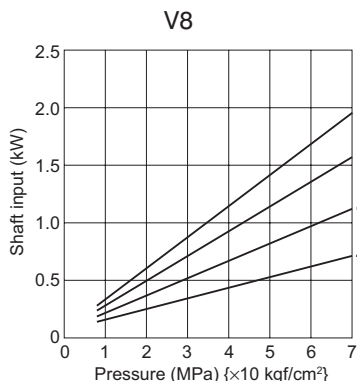

Drainage volume characteristics

Common to 1800 min⁻¹ and 1500 min⁻¹ Fluid used: ISO VG32, Fluid Temperature: 50°C

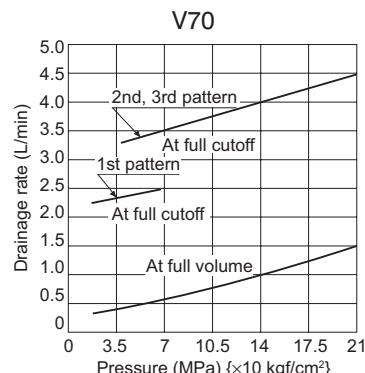
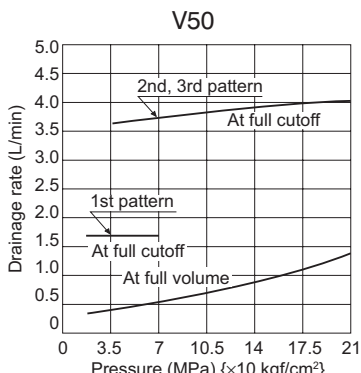
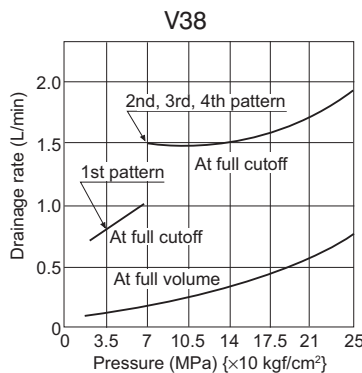
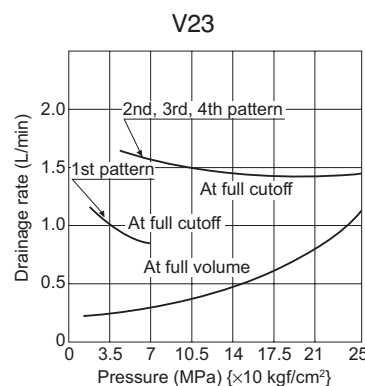
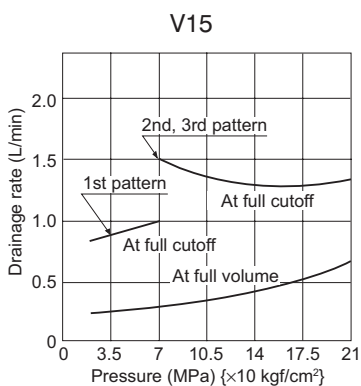
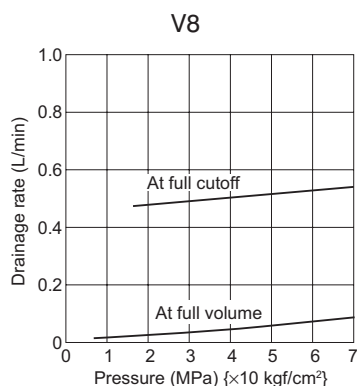

Sectional structural diagram

V8, V15

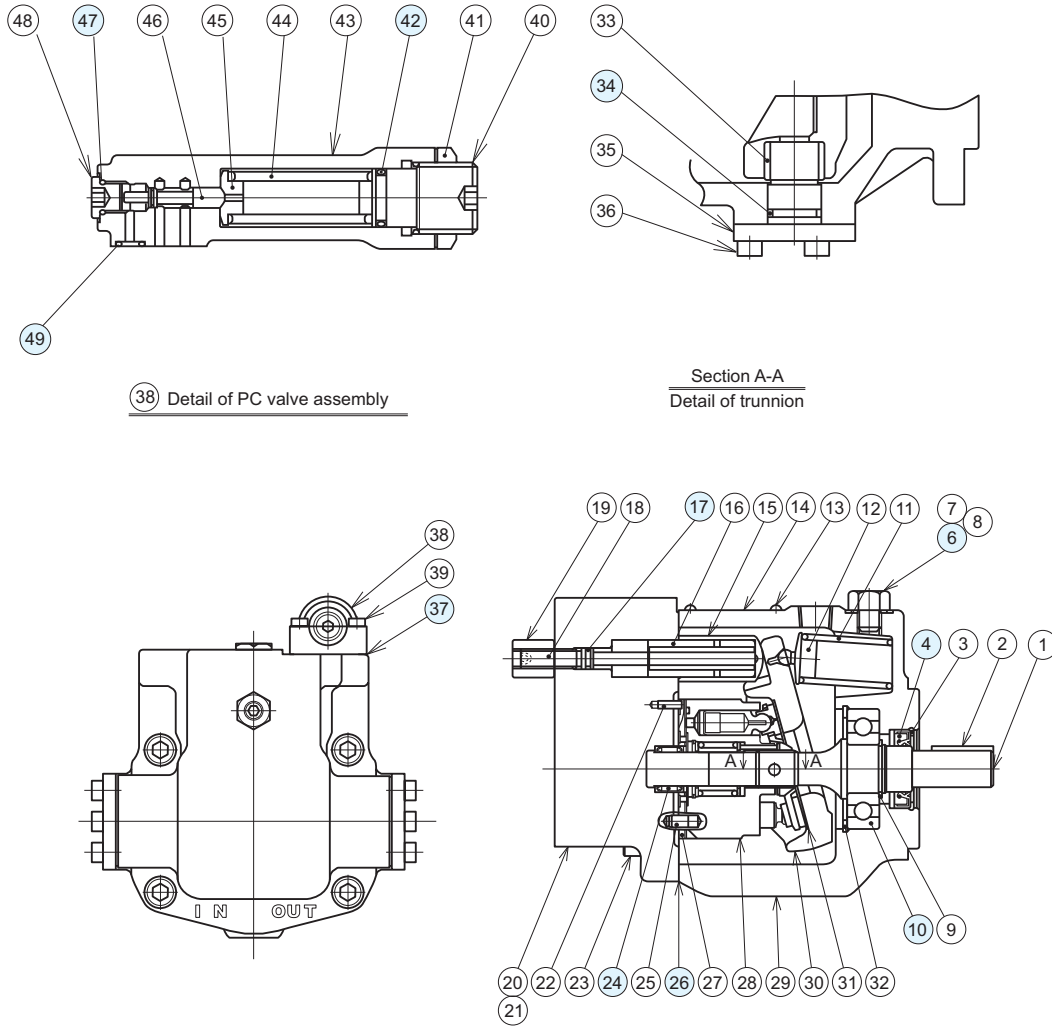

38 Detail of PC valve assembly

Section A-A
Detail of trunnion

V8 Seal/bearing table

Part No.	Name	Specifications	Material	Quantity
4	Oil seal	TCV19358	NBR	1
6	Sealing washer	WF12192	NBR	1
10	Ball bearing	6004		1
17	O-ring	JIS B 2401 1A-P4	NBR	1
24	Needle bearing	HK1210		1
26	Gasket	1730500 (special part)		1
34	O-ring	JIS B 2401 1A-P20	NBR	2
37	Gasket	1741116 (special part)		1
42	O-ring	JIS B 2401 1B-P14	NBR	1
47	O-ring	AS568-903 (HS90)	NBR	1
49	O-ring	JIS B 2401 1B-P6	NBR	1

V15 Seal/bearing table

Part No.	Name	Specifications	Material	Quantity
4	Oil seal	TCV24408	NBR	1
6	Sealing washer	WF12192	NBR	1
10	Ball bearing	6305		1
17	O-ring	JIS B 2401 1A-P8	NBR	1
24	Needle bearing	FJL1715		1
26	Gasket	1730390 (special part)		1
34	O-ring	JIS B 2401 1A-P18	NBR	2
37	Gasket	1740698 (special part)		1
42	O-ring	JIS B 2401 1B-P14	NBR	1
47	O-ring	AS568-903 (HS90)	NBR	1
49	O-ring	JIS B 2401 1B-P6	NBR	1

Sectional structural diagram

V23, V38

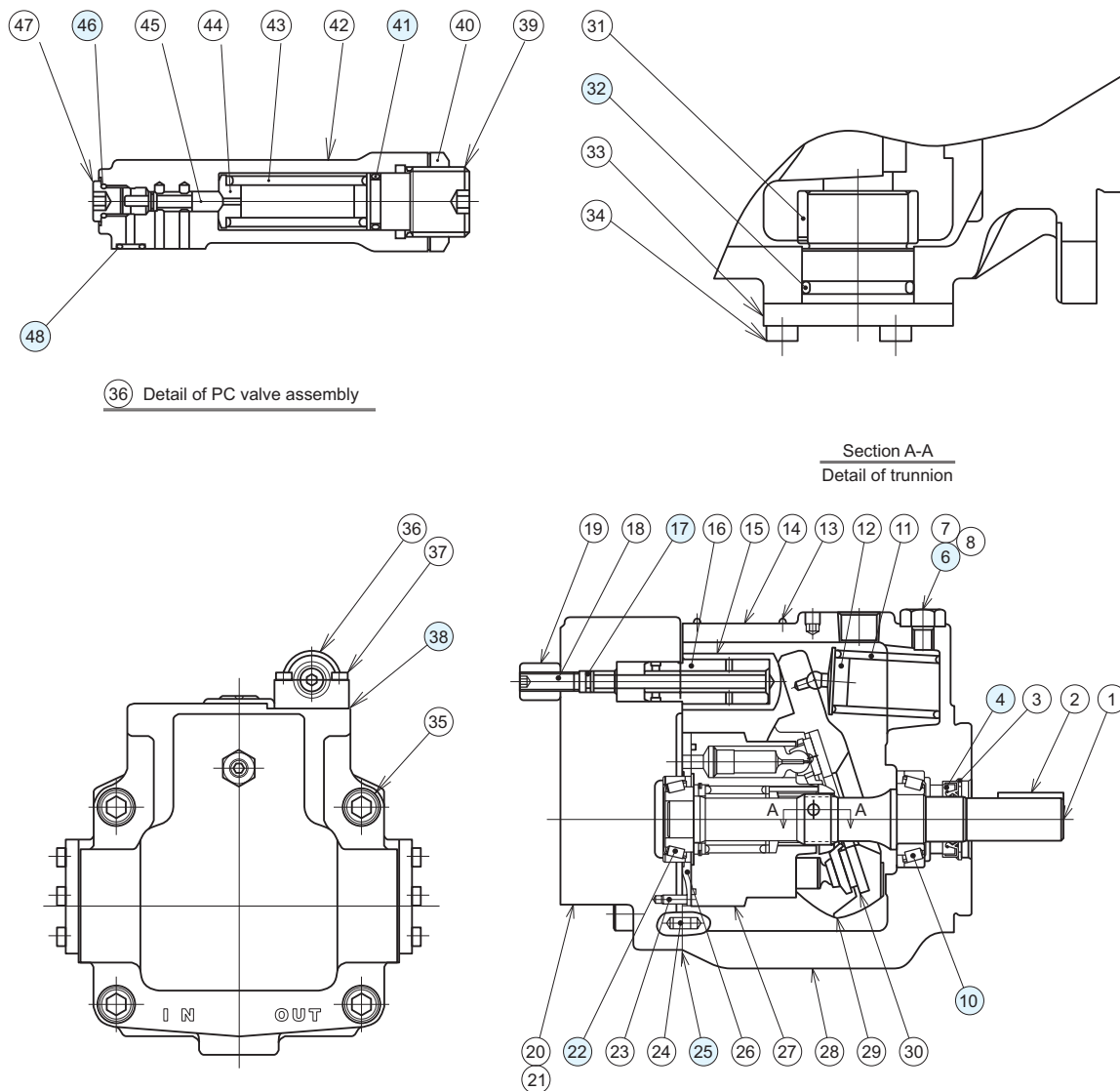

V23 Seal/bearing table

Part No.	Name	Specifications	Material	Quantity
4	Oil seal	TCV24408	NBR	1
6	Sealing washer	WF12192	NBR	1
10	Tapered roller bearing	Cup: 4T-L44610/ Cone: 4T-L44643		1
17	O-ring	JIS B 2401 1A-P8	NBR	1
22	Tapered roller bearing	Cup: 4T- LM11710/ Cone: 4T- LM11749		1
25	Gasket	1730511 (special part)		1
32	O-ring	JIS B 2401 1A-G30	NBR	2
38	Gasket	1740698 (special part)		1
41	O-ring	JIS B 2401 1B-P14	NBR	1
46	O-ring	AS568-903 (HS90)	NBR	1
48	O-ring	JIS B 2401 1B-P6	NBR	1

V38 Seal/bearing table

Part No.	Name	Specifications	Material	Quantity
4	Oil seal	TCV24408	NBR	1
6	Sealing washer	WF12192	NBR	1
10	Tapered roller bearing	Cup: 4T-L44610/ Cone: 4T-L44643		1
17	O-ring	JIS B 2401 1A-P8	NBR	1
22	Tapered roller bearing	Cup: 4T- LM11910/ Cone: 4T- LM11949		1
25	Gasket	1730500 (special part)		1
32	O-ring	JIS B 2401 1A-G30	NBR	2
38	Gasket	1740698 (special part)		1
41	O-ring	JIS B 2401 1B-P14	NBR	1
46	O-ring	AS568-903 (HS90)	NBR	1
48	O-ring	JIS B 2401 1B-P6	NBR	1

Sectional structural diagram

V50, V70

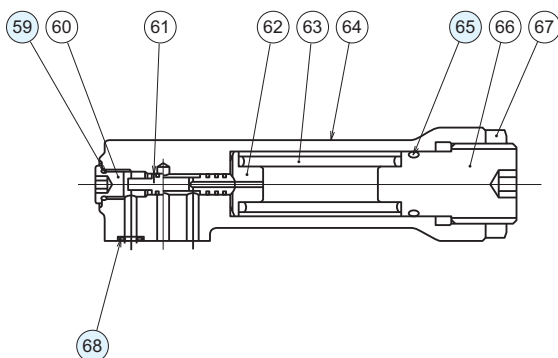

58 Detail of PC valve assembly

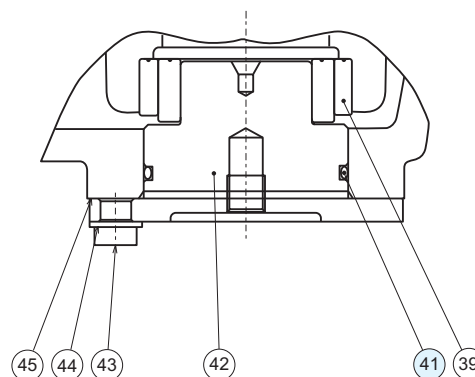

Section A-A
Detail of trunnion

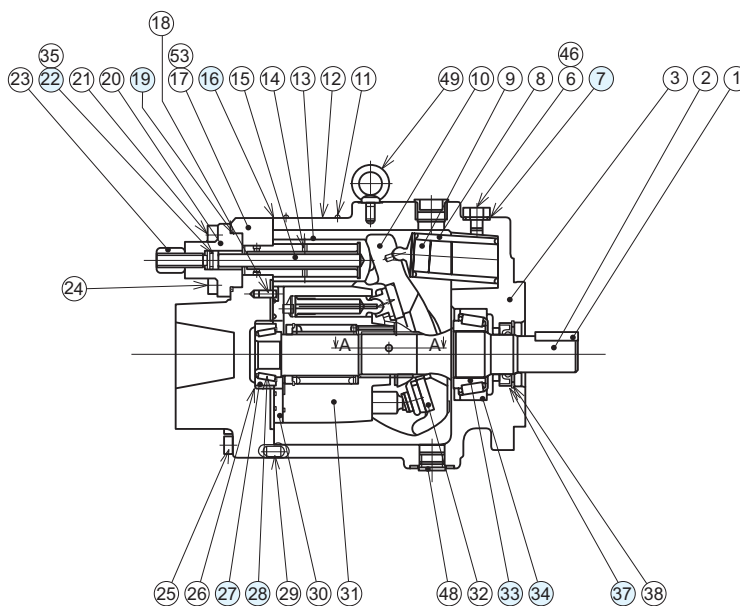
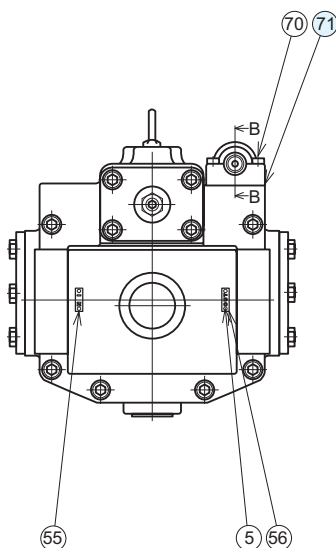

V50 Seal/bearing table

Part No.	Name	Specifications	Material	Quantity
7	Sealing washer	WF12192	NBR	1
16	Gasket	1020257 (special part)		1
19	O-ring	JIS B 2401 1A-G50	NBR	1
22	O-ring	JIS B 2401 1A-P12	NBR	1
27	Tapered roller bearing	Cup: 21212 Sa		1
28	Tapered roller bearing	Cone: 21075 Sa		1
33	Tapered roller bearing	Cone: 4T-344A P × 2		1
34	Tapered roller bearing	Cup: 4T-332 P × 2		1
37	Oil seal	TCV355511	NBR	1
41	O-ring	AS568-228 (HS70)	NBR	2
59	O-ring	AS568-903 (HS90)	NBR	1
65	O-ring	JIS B 2401 1A-P18	NBR	1
68	O-ring	JIS B 2401 1B-P6	NBR	1
71	Gasket	1740975 (special part)		1

V70 Seal/bearing table

Part No.	Name	Specifications	Material	Quantity
7	Sealing washer	WF12192	NBR	1
16	Gasket	1730446 (special part)		1
19	O-ring	JIS B 2401 1A-G50	NBR	1
22	O-ring	JIS B 2401 1A-P12	NBR	1
27	Tapered roller bearing	Cup: 4T-M84210		1
28	Tapered roller bearing	Cone: 4T-M84249		1
33	Tapered roller bearing	Cone: 4T-3386		1
34	Tapered roller bearing	Cup: 4T-3320		1
37	Oil seal	TCV355511	NBR	1
41	O-ring	AS568-230 (HS70)	NBR	2
59	O-ring	AS568-903 (HS90)	NBR	1
65	O-ring	JIS B 2401 1A-P18	NBR	1
68	O-ring	JIS B 2401 1B-P6	NBR	1
71	Gasket	1740975 (special part)		1

VZ series Piston Pump

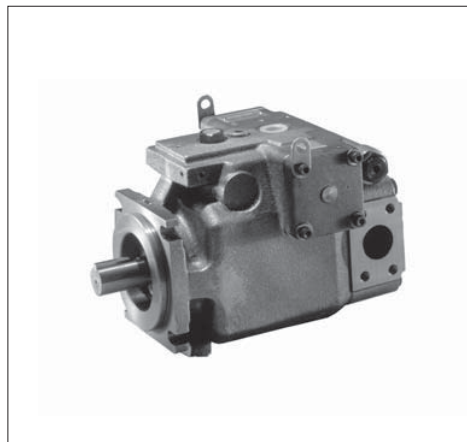

Features

- **Highly intensified output**
Adopting the cradle swash plate has achieved high pressure in a compact and light-weight body, resulting in increased output per unit weight.
- **Low noise**
While increasing the rigidity of the swash plate structure, the noise level has been substantially reduced thanks to the housing geometry resulting from the state-of-the-art measurement and analysis technologies.
- **High efficiency**
The spherical valve plate and optimum hydraulic balance realize stable and highly efficient operation over a broad range of operation conditions.
- **Long life**
Adopting the spherical valve plate with its superior abrasion resistance has improved the anti-contaminant characteristics.

Nomenclature

- Pressure compensator control

VZ ※ ※ ※ A ※ R X - 10 ※ ※

1 2 3 4 7 10 11 12

- Combination control

VZ ※ ※ ※ C ※ ※ R ※ ※ X - 10

1 2 3 5 6 7 8 9 10 11

1 Model No.

VZ: VZ series piston pump *1

2 Pump capacity

- 50: 50.2 cm³/rev
- 63: 63.0 cm³/rev
- 80: 79.6 cm³/rev
- 100: 104.6 cm³/rev
- 130: 135.9 cm³/rev

3 Control method I (Refer to Page A-4 for the applicable models.)

- A: Pressure compensator control
- C: Combination control *2

4 Pressure adjustment range

- 1: 1.5 to 7 MPa {15 to 70 kgf/cm²}
- 2: 1.5 to 14 MPa {15 to 140 kgf/cm²}
- 3: 3.5 to 21 MPa {35 to 210 kgf/cm²}
- 4: 3.5 to 28 MPa {35 to 280 kgf/cm²} *3

5 Low pressure adjustment range

- 1: 1.5 to 7 MPa {15 to 70 kgf/cm²}
- 2: 1.5 to 14 MPa {15 to 140 kgf/cm²}
- 3: 3.5 to 21 MPa {35 to 210 kgf/cm²}
- 4: 3.5 to 28 MPa {35 to 280 kgf/cm²} *3

6 High pressure adjustment range

- 1: 1.5 to 7 MPa {15 to 70 kgf/cm²}
- 2: 1.5 to 14 MPa {15 to 140 kgf/cm²}
- 3: 3.5 to 21 MPa {35 to 210 kgf/cm²}
- 4: 3.5 to 28 MPa {35 to 280 kgf/cm²} *3

7 Direction of rotation, when viewed from the shaft end

R: Clockwise (rightward)

8 Control method II

- H: Pressure feedback method
- J: Solenoid operated method

9 Voltage code for the solenoid valve

<Applied only when control method II is J>

- A: AC 100 V (50/60 Hz), AC 110 V (60 Hz)
- B: AC 200 V (50/60 Hz), AC 220 V (60 Hz)
- P: DC 12 V

10 Piping direction

X: Side port

11 Design No. (The design No. is subject to change)

12 Control method III

- No designation: Without remote control system
 - RC: With remote control system *4
- <Applied only when control method I is A>

Note: *1 Only petroleum-based hydraulic fluids are acceptable for the VZ series.

*2 The combination control is not applicable to VZ130.

*3 The 4th pattern of the pressure adjustment range (3.5 to 28 MPa {35 to 280 kg/cm²}) applies only to VZ50, VZ63, VZ80, and VZ100.

*4 The pressure adjustment range with a remote control system is the 4th pattern only (but the 3rd pattern for VZ130).

Note: JR-G (T) 02 and JRP-G02 are recommended for the remote control system's relief valve.

If the vent port is blocked, the pressure compensation structure does not work and the pump operates at a fixed pressure.

● Foot supports and piping flanges are not provided with the pump. Order them separately as required by referring to Pages S-2 to S-4.

Models and pressure adjustment range table

● Pressure compensator control

4 Pressure adjustment range

Code	Pressure adjustment range MPa {kgf/cm ² }	Without remote control system					With remote control system				
		VZ50	VZ63	VZ80	VZ100	VZ130	VZ50	VZ63	VZ80	VZ100	VZ130
1	1.5 to 7 { 15 to 70}	✓	✓	✓	✓	✓	-	-	-	-	-
2	1.5 to 14 { 15 to 140}	✓	✓	✓	✓	✓	-	-	-	-	-
3	2 to 21 { 20 to 210}	-	-	-	-	-	-	-	-	-	✓
3	3.5 to 21 {135 to 210}	✓	✓	✓	✓	✓	-	-	-	-	-
4	2 to 28 { 20 to 280}	-	-	-	-	-	✓	✓	✓	✓	-
4	3.5 to 28 { 35 to 280}	✓	✓	✓	✓	-	-	-	-	-	-

● Combination control

5 Low pressure adjustment range

Code	Pressure adjustment range MPa {kgf/cm ² }	Without remote control system			
		VZ50	VZ63	VZ80	VZ100
1	1.5 to 7 {15 to 70}	✓	✓	✓	✓
2	1.5 to 14 {15 to 140}	✓	✓	✓	✓
3	3.5 to 21 {35 to 210}	✓	✓	✓	✓
4	3.5 to 28 {35 to 280}	✓	✓	✓	✓

6 High pressure adjustment range

Code	Pressure adjustment range MPa {kgf/cm ² }	Without remote control system							
		Pressure feedback method				Solenoid operated method			
		VZ50	VZ63	VZ80	VZ100	VZ50	VZ63	VZ80	VZ100
1	1.5 to 7 {15 to 70}	✓	✓	✓	✓	✓	✓	✓	✓
2	1.5 to 14 {15 to 140}	✓	✓	✓	✓	✓	✓	✓	✓
3	3.5 to 21 {35 to 210}	✓	✓	✓	✓	✓	✓	✓	✓
4	3.5 to 28 {35 to 280}	✓	✓	✓	✓	✓	✓	✓	✓

Specifications

Model No.	Theoretical discharge rate cm ³ /rev	Maximum operating pressure MPa {kgf/cm ² }	Permissible rotational speed min ⁻¹	Discharge rate adjustment range 1800min ⁻¹ L/min	Mass (Control method A) kg
VZ50	50.2	28 {280}	500 to 1800	0 to 90	40
VZ63	63.0	28 {280}	500 to 1800	0 to 113	47
VZ80	79.6	28 {280}	500 to 1800	0 to 143	55
VZ100	104.6	28 {280}	500 to 1800	0 to 188	75
VZ130	135.9	21 {210}	500 to 1800	0 to 244	105

- Foot supports and piping flanges are not provided with the pump. Order them separately as required by referring to Pages S-2 to S-4.

Pressure adjustment methods

● Pressure compensator control

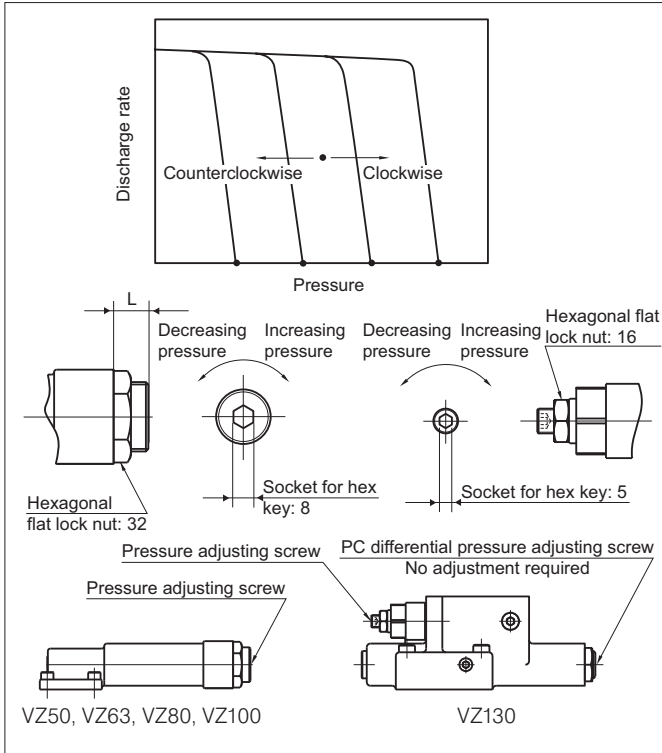

Variation of discharge pressure

VZ50, VZ63
VZ80, VZ100

As shown in the graph to the right

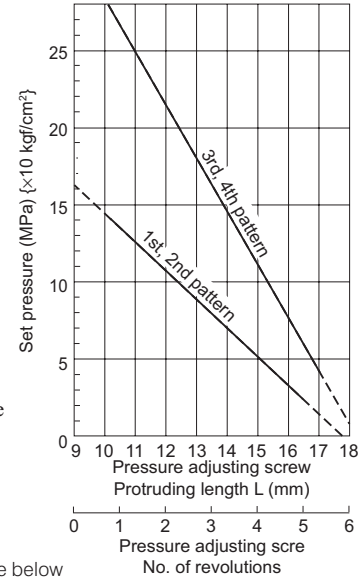

○ The 1st to 4th patterns correspond to the pressure adjustment range designation codes 1 to 4.

VZ130: As shown in the table below

Pressure adjustment range code	Discharge pressure variation/one revolution of the pressure adjusting screw
1	2.5 MPa/revolution
2	4.6 MPa/revolution
3	7.9 MPa/revolution

● Combination control

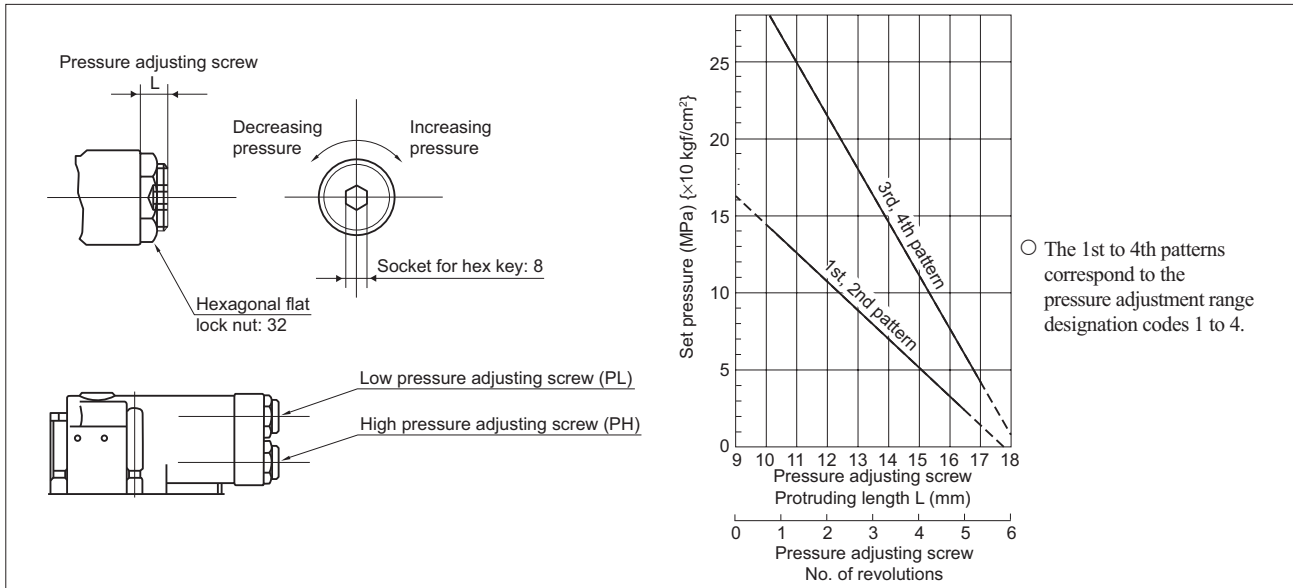

Pressure adjustment range [Common to the pressure feedback method (CH) and solenoid operated method (CJ)]

Pressure type	Low pressure adjustment range	High pressure adjustment range
1	1.5 to 7 MPa {15 to 70 kgf/cm ² }	1.5 to 7 MPa {15 to 70 kgf/cm ² }
2	1.5 to 14 MPa {15 to 140 kgf/cm ² }	1.5 to 14 MPa {15 to 140 kgf/cm ² }
3	3.5 to 21 MPa {35 to 210 kgf/cm ² }	3.5 to 21 MPa {35 to 210 kgf/cm ² }
4	3.5 to 28 MPa {35 to 280 kgf/cm ² }	3.5 to 28 MPa {35 to 280 kgf/cm ² }

● The exact characteristics of the solenoid operated type combination control will be as shown to the right. To be more specific, even if the solenoid is turned on to switch to high pressure operation the discharge rate will not switch to the low quantity range (QL) until the pressure in the circuit reaches the pressure P1 that overcomes the bias spring force that inclines the swash plate.

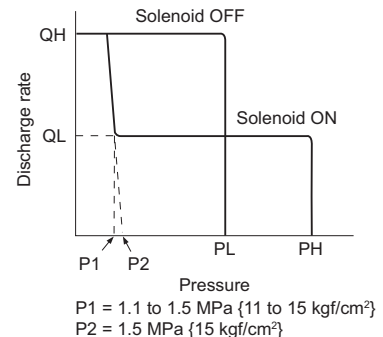

Relationship between the protruding length of the discharge rate adjusting screw and the discharge rate (pressure compensator control)

The maximum discharge rate can be set to the desired value by turning the discharge rate adjusting screw at the side of the housing.

- Turning the adjusting screw clockwise decreases the discharge rate.
- Turning the adjusting screw counterclockwise increases the discharge rate.

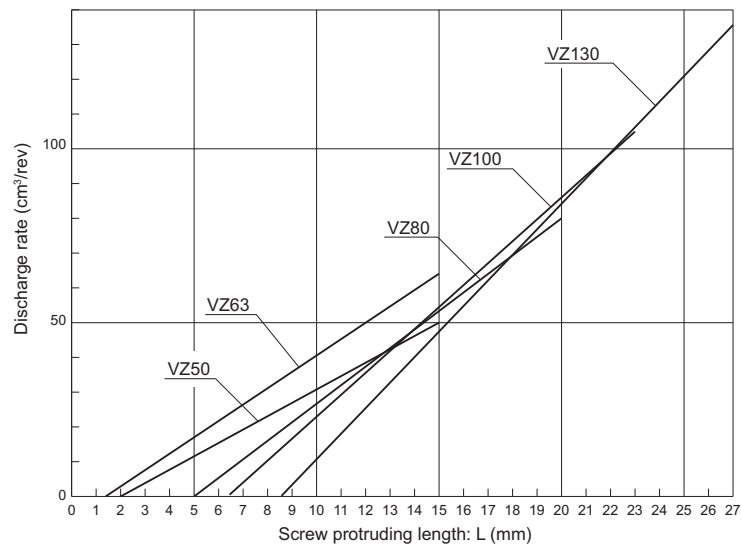
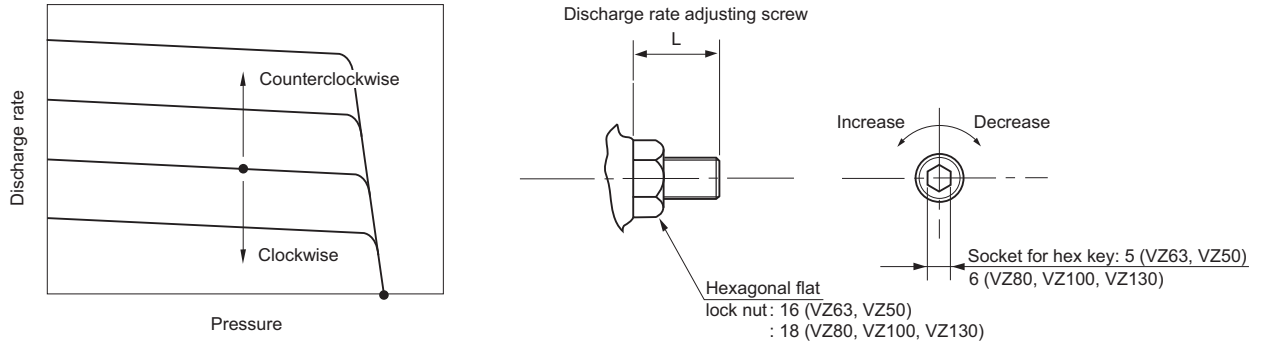

Relationship between the protruding length of the discharge rate adjusting screw and the discharge rate (combination control)

- The discharge rate adjusting screws are provided with scales as shown below.
- Turning the adjusting screw clockwise decreases the discharge rate.
- Turning the adjusting screw counterclockwise increases the discharge rate.

Pump model	Scale °	
	Low quantity adjusting screw	High quantity adjusting screw
VZ50C	0 to 10	0 to 17
VZ63C	0 to 10	0 to 17
VZ80C	0 to 10	0 to 17
VZ100C	0 to 10	0 to 17

(Scale graduation: 1°)

Note: The high quantity adjustment range may be restricted due to the setting for the low quantity range. See the graphs on Page A-49 for details.

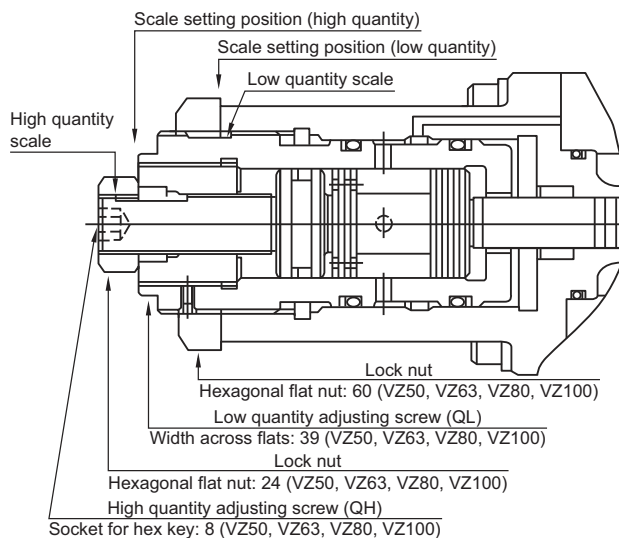

Adjust the discharge rate according to the relevant discharge rate adjustment graph by following the procedure below.

- For the low quantity range, read the value for the desired discharge rate on the graph and turn the low quantity adjusting screw to set the scale position to the read value.
- For the high quantity range, read the value for the desired discharge rate on the line corresponding to the value for the low quantity range on the graph and turn the high quantity adjusting screw to set the scale position to the read value.
- When adjusting only the high quantity range, loosen the lock nut and adjust as described above.
- When adjusting only the low quantity range, loosen the lock nut on the high quantity adjustment screw and adjust the setting for the low quantity range as described above while holding the high quantity adjusting screw in place with a hex key.

Example of adjustment

When adjusting the discharge rate of VZ80C to 23 cm³/rev for the low quantity range (QL) and 75 cm³/rev for the high quantity range (QH)

- (1) From the discharge rate adjustment graph for VZ80C in combination control, first read the value for QL = 23 cm³/rev, which is 5°, and adjust the low quantity adjusting screw accordingly.
- (2) Then, read the value for QH = 75 cm³/rev on the line for 5° of QL, which is 11°, and adjust the high quantity adjusting screw accordingly.

Discharge rate adjustment graph for VZ80C in combination control

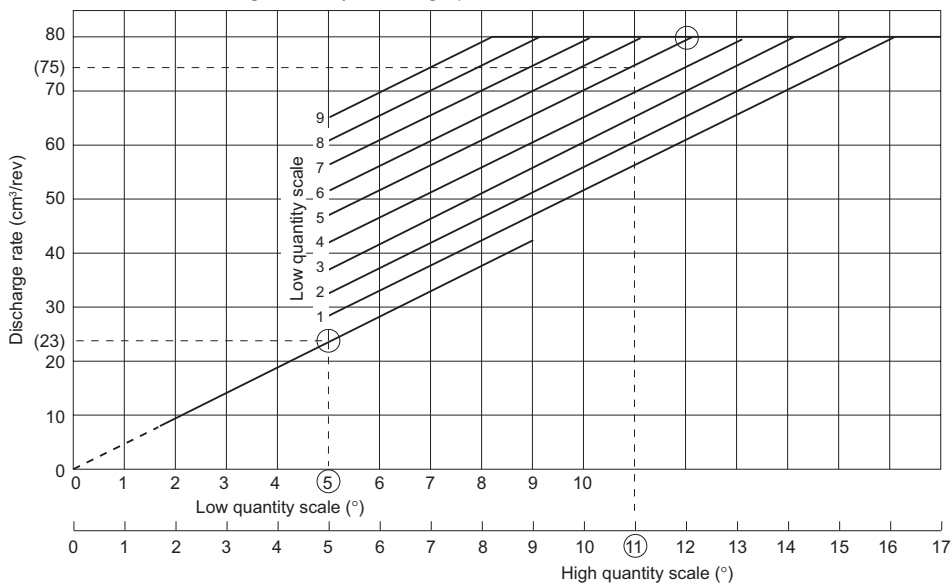

- The setting values indicated above may change slightly depending on the conditions of use (fluid temperature, hydraulic fluid type, etc.) For final fine adjustment, repeat the adjustment described above and achieve the setting appropriate for the actual application.

■ **Factory setting of discharge rate**

The discharge rate for the high quantity range is factory adjusted to the maximum discharge rate and the discharge rate for the low quantity range is factory adjusted as follows.

Pump model	Low quantity (QL) setting
VZ50C	Scale position: 4°
VZ63C	Scale position: 4°
VZ80C	Scale position: 4°
VZ100C	Scale position: 4°

Discharge rate adjustment graph in combination control

Linear adjustment of the discharge rate for the low quantity range is not possible below the adjustment range (section indicated by the dashed line).

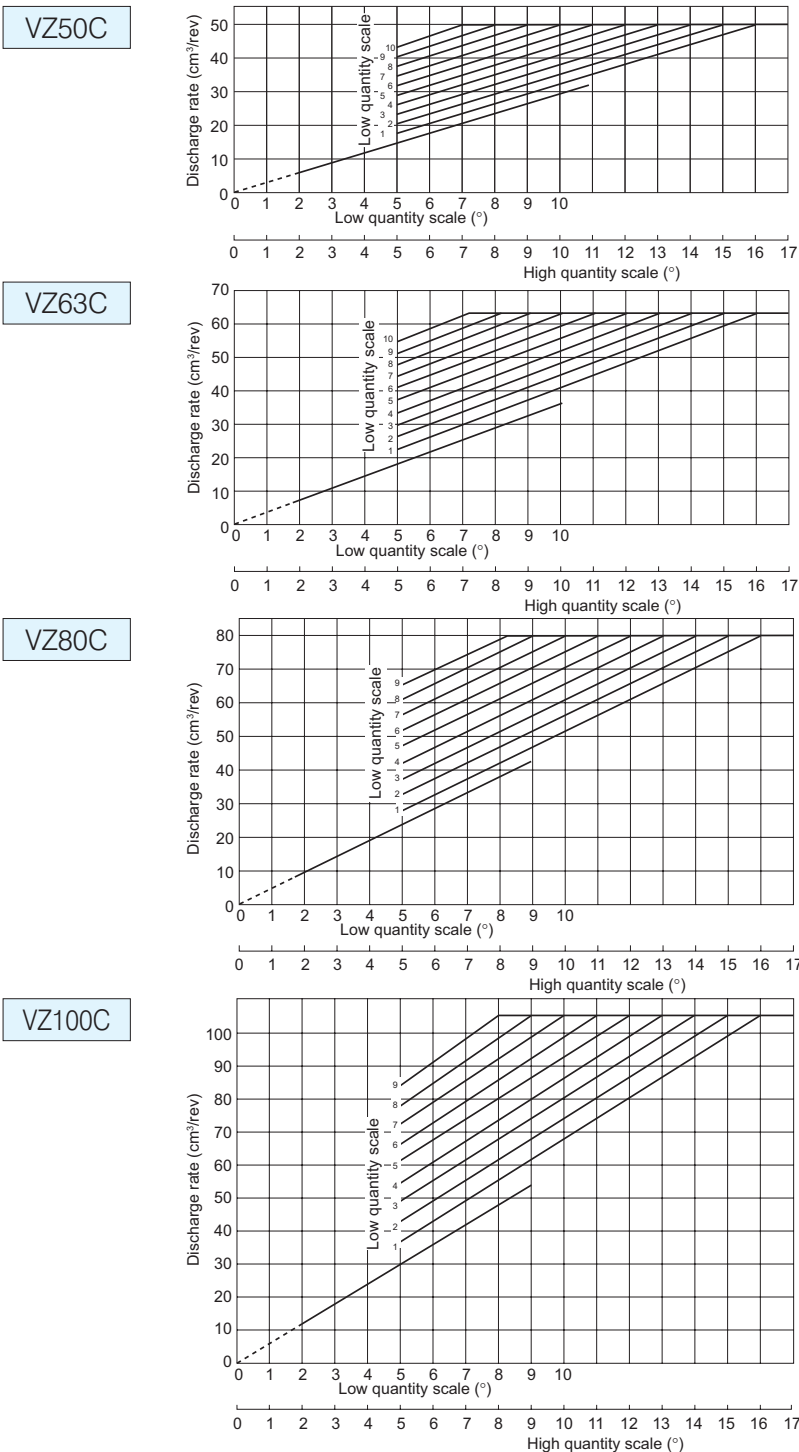

General performance (1800 min⁻¹)

Discharge rate setting: maximum

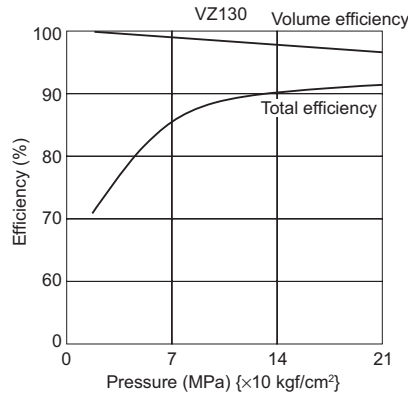
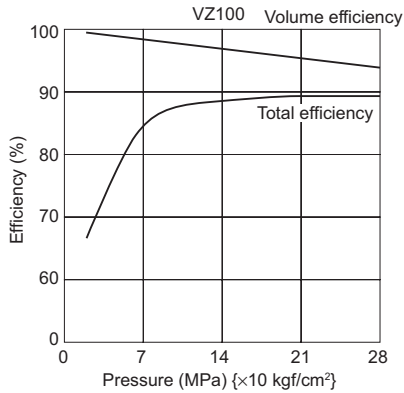
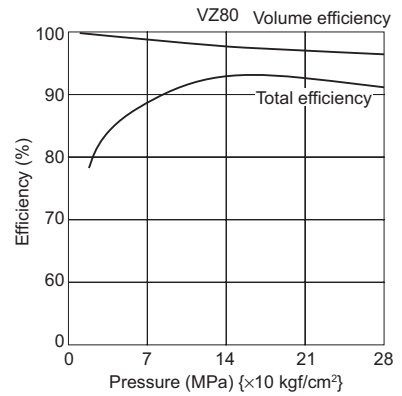
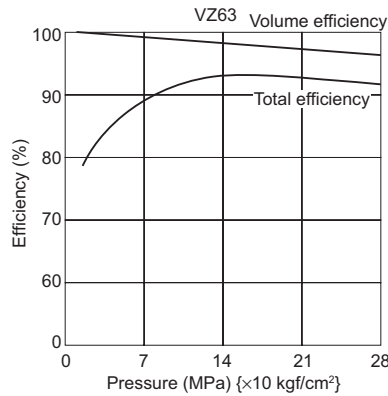
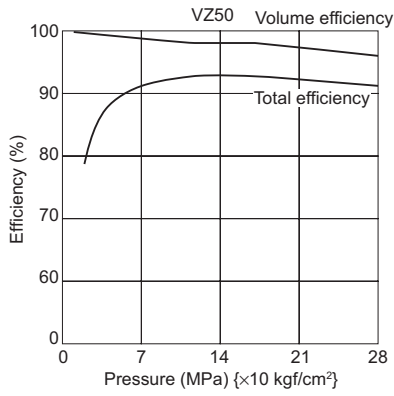

Note: The efficiency varies depending on the discharge rate setting. When selecting the motor capacity, refer to the shaft input characteristics on Page A-52.

Shaft input characteristics at full cutoff (1800 min⁻¹)

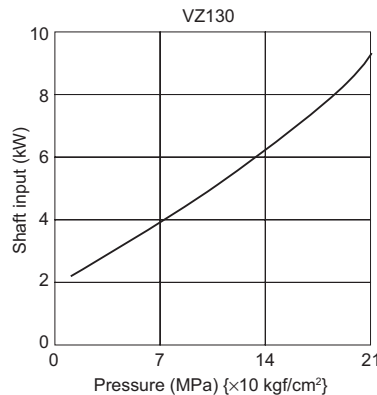
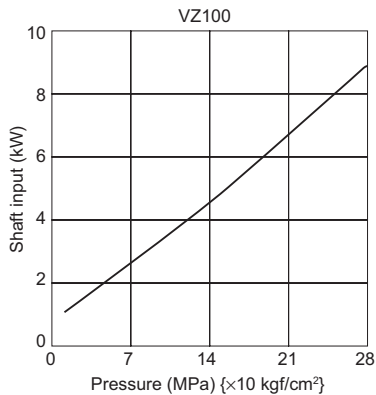
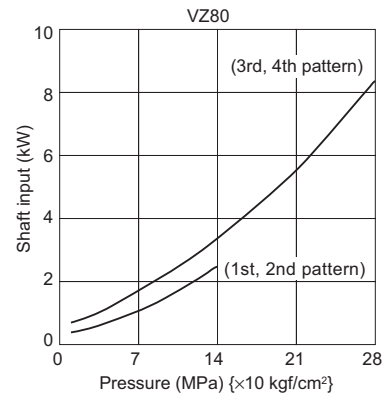
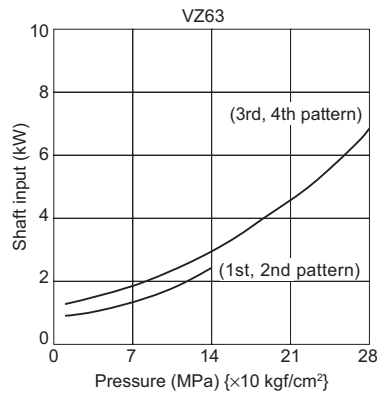
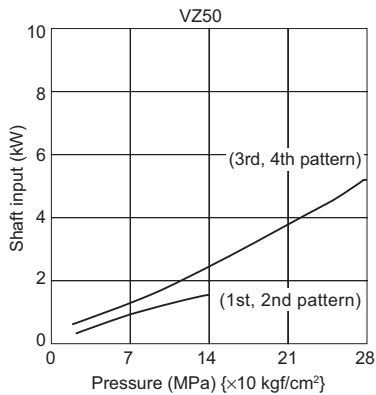

General performance (1500 min⁻¹)

Discharge rate setting: maximum

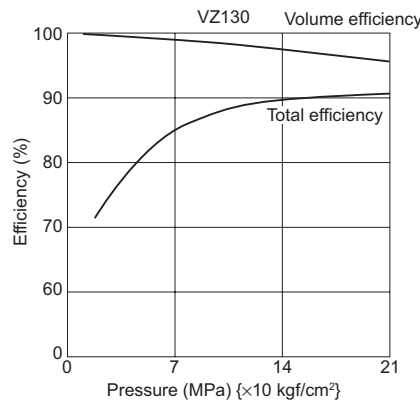
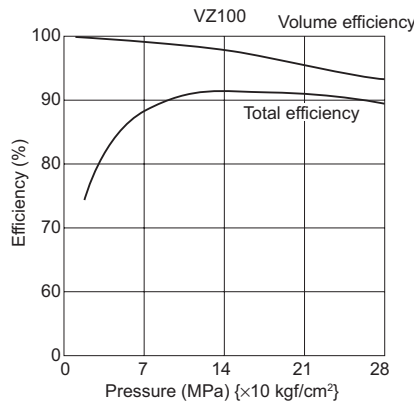
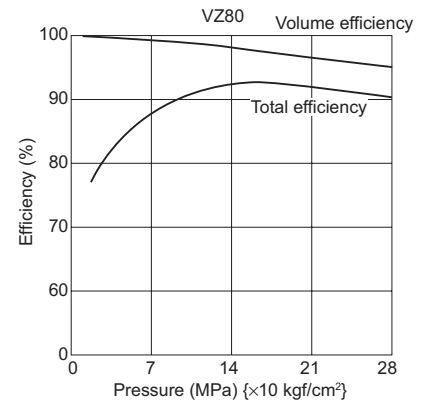
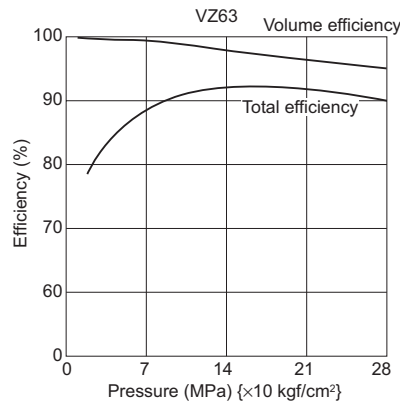
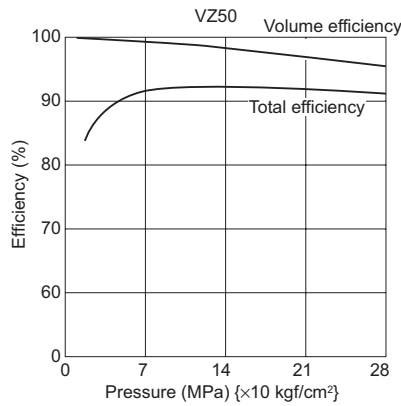

Note: The efficiency varies depending on the discharge rate setting. When selecting the motor capacity, refer to the shaft input characteristics on Page A-53.

Shaft input characteristics at full cutoff (1500 min⁻¹)

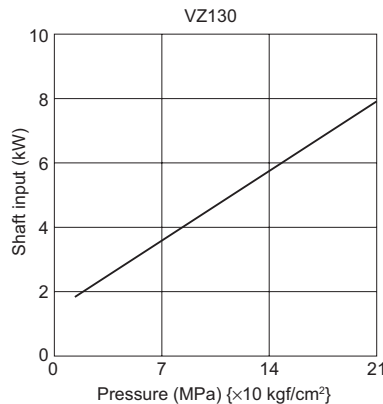
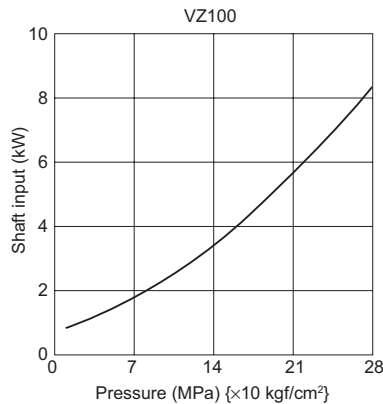
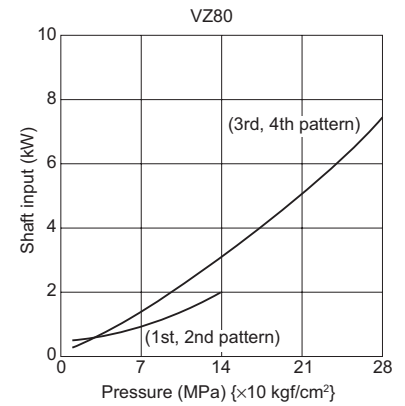
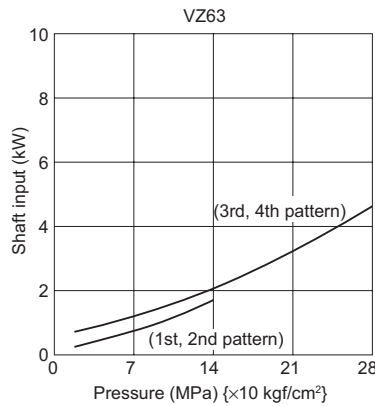
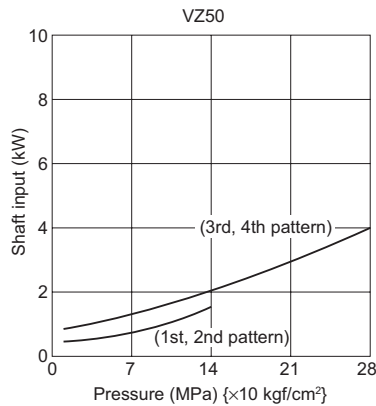

Shaft input characteristics (1800 min⁻¹)

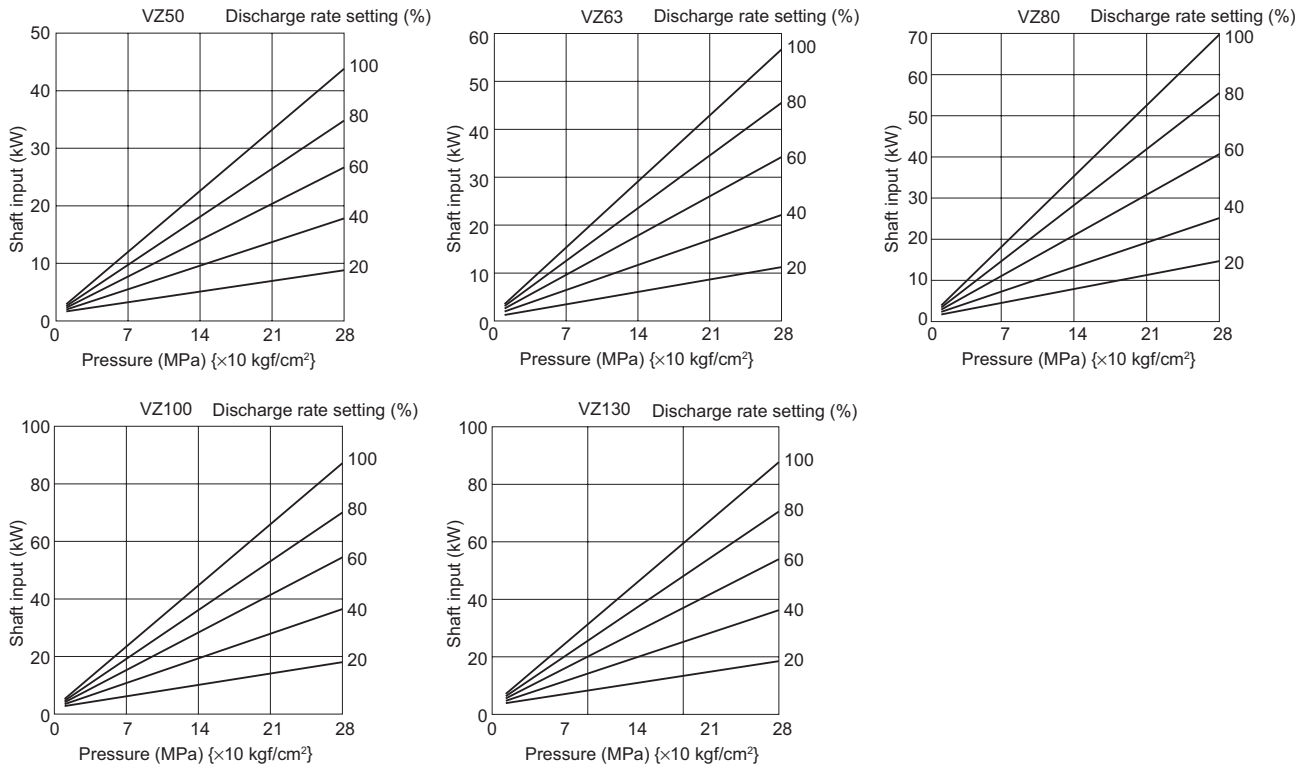

Drainage volume characteristics (1800 min⁻¹)

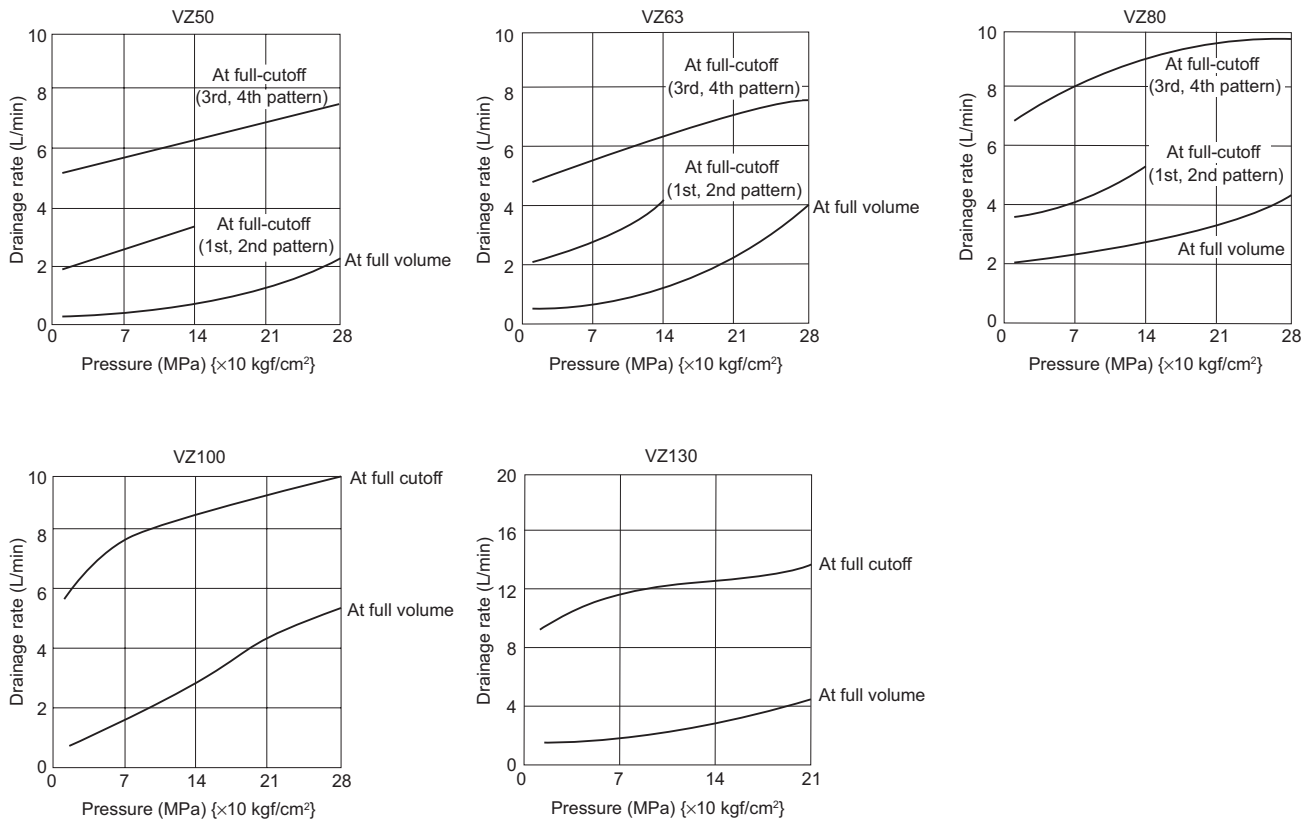

Shaft input characteristics (1500 min⁻¹)

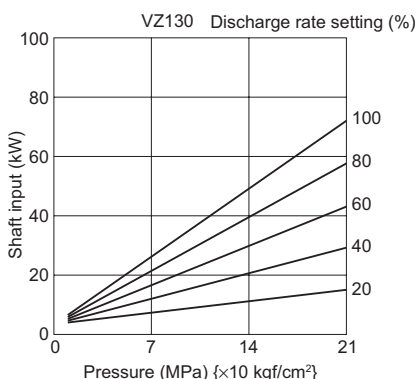
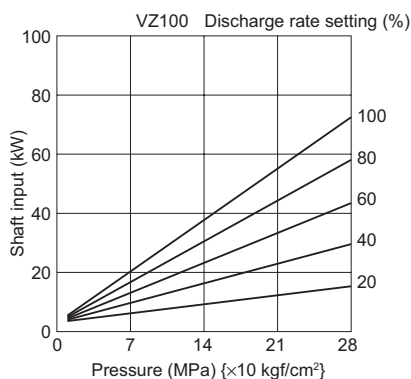
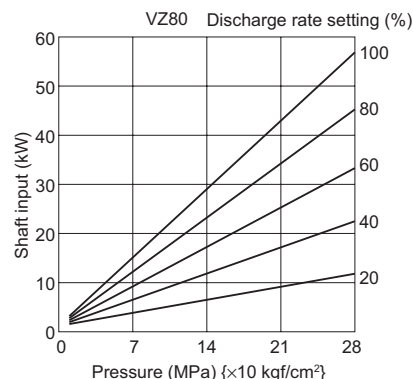
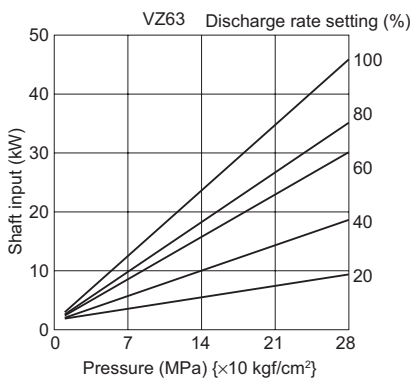
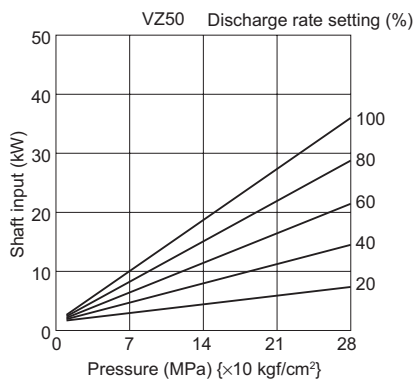

Drainage volume characteristics (1500 min⁻¹)

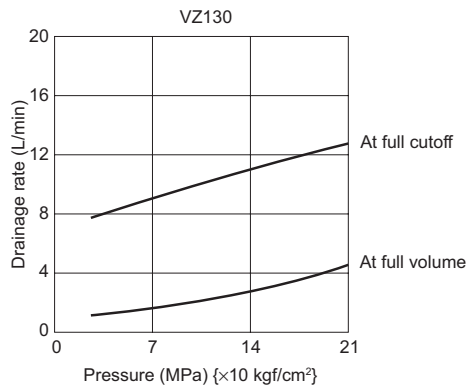
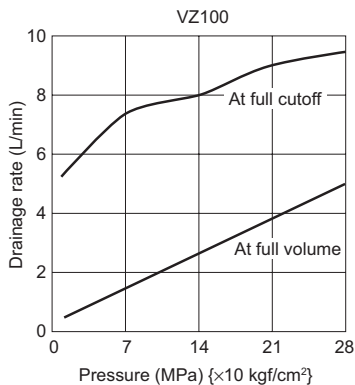
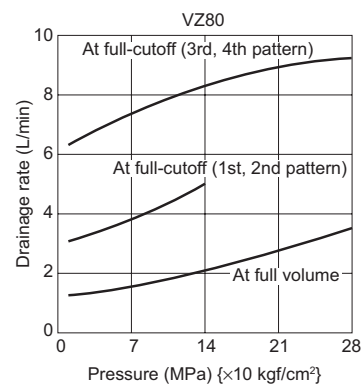
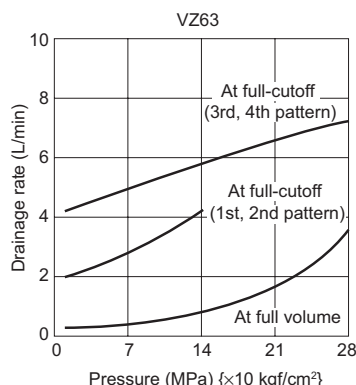
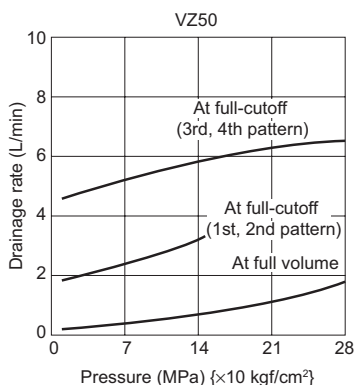

Noise characteristics (JIS B 8350, measuring position: 1 m from pump front)

Input rotational speed	Fluid used	Oil temperature
1800 min ⁻¹ 1500 min ⁻¹	Equivalent to ISO VG32	50°C

----- 1500 min⁻¹
 _____ 1800 min⁻¹

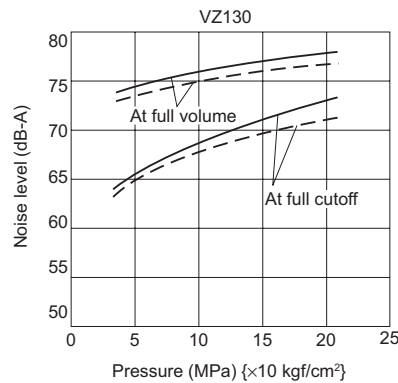
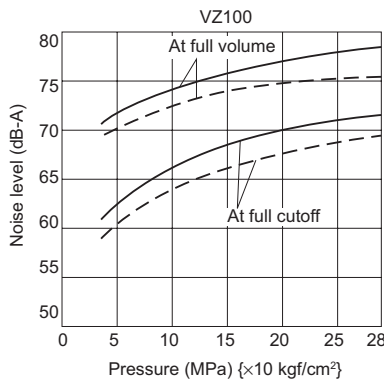
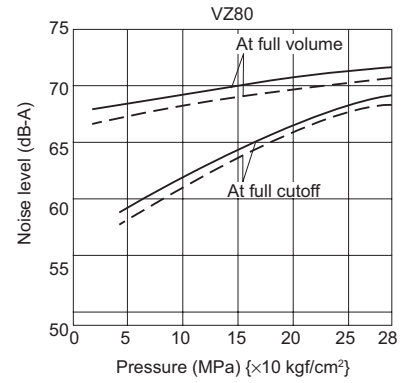
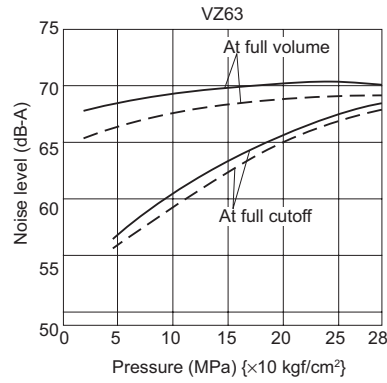
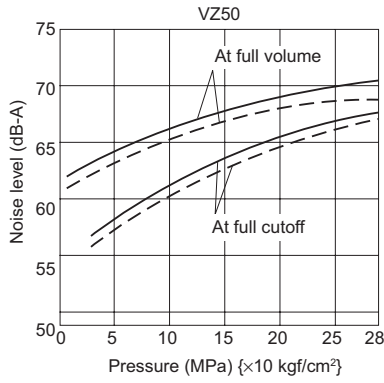

Sectional structural diagram

VZ80

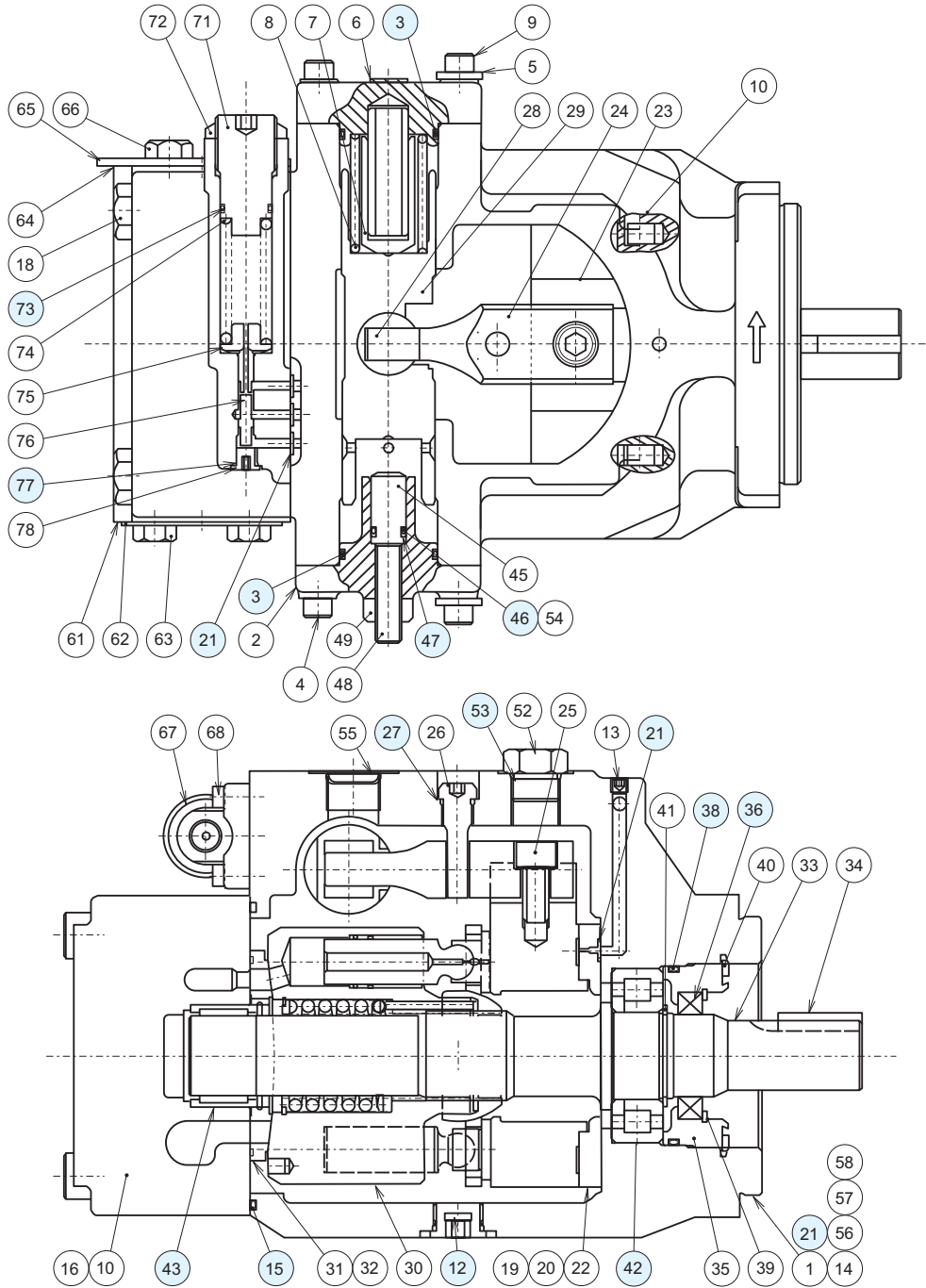

Part No.	Part name	VZ130	VZ100	VZ80	VZ63	VZ50	Material	Quantity
		Specifications						
3	O-ring	JIS B 2401 1B-G45		JIS B 2401 1B-G40	JIS B 2401 1B-G35		NBR	2
12	O-ring	AS568-910 (HS90)				AS568-908 (HS90)	NBR	1
15	O-ring	JIS B 2401 1A-G160	JIS B 2401 1A-G150	JIS B 2401 1B-G135	JIS B 2401 1B-G125	JIS B 2401 1B-G120	NBR	1
21	O-ring	JIS B 2401 1B-P7					NBR	6
27	O-ring	AS568-908 (HS90)					NBR	1
36	Oil seal	TCN487012		TCV385811		TCV284811	NBR	1
38	O-ring	AS568-238 (HS70)		AS568-234 (HS70)			NBR	1
42	Cylinder roller bearing	NUP2210G1C3	NUP2210G1C3	NUP2208C3	NUP208C3	NUP2206C3		1
43	Needle bearing	NK43/30RV1+IR384330C	NK40/30RV1+IR354030C	NK37/30RV1	NK32/30RV2	NK29/30RV1		1
46	O-ring	JIS B 2401 1B-P12			JIS B 2401 1B-P10A		NBR	1
47	Backup ring	JIS B 2407 T2P12			JIS B 2407 T2P10A			1
53	O-ring	AS568-910 (HS90)					NBR	1
73	O-ring	JIS B 2401 1B-P20					NBR	1
77	O-ring	AS568-903 (HS90)					NBR	1

VD series Dual Pump

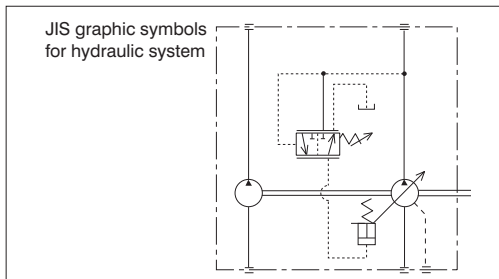
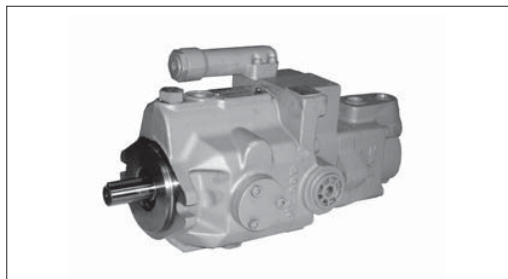

Nomenclature



1 Model No.

VD: VD series Dual Pump

2 Vane pump capacity code

- 1: DS11P
- 2: DS12P
- 3: DS13P
- 4: DS14P

3 Piston pump capacity code

- 8: V 8 (8.0 cm³/rev)
- 15: V15 (14.8 cm³/rev)
- 38: V38 (37.7 cm³/rev)

4 Control method

A: Pressure compensator control

5 Pressure adjustment range (piston pump)

- 1: 0.8 to 7 MPa { 8 to 70 kgf/cm²}
- 2: 1.5 to 14 MPa {15 to 140 kgf/cm²}
- 3: 3.5 to 21 MPa {35 to 210 kgf/cm²}

6 Direction of rotation, when viewed from the shaft end

R: Clockwise (rightward)

7 Design No. (The design No. is subject to change)

- 30: Pump model VD※-8A1R
- 95: Pump model VD※-15A※R, VD※-38A※R

Vane Pump Specifications

[Conditions] Input rotational speed: 1800 min⁻¹, Fluid used: equivalent to ISO VG32, Fluid temperature: 40°C

Model code	Discharge rate L/min				Shaft input kW				
	0.4 MPa {4 kgf/cm ² }	3 MPa {30 kgf/cm ² }	5 MPa {50 kgf/cm ² }	7 MPa {70 kgf/cm ² }	0.4 MPa {4 kgf/cm ² }	1 MPa {10 kgf/cm ² }	3 MPa {30 kgf/cm ² }	5 MPa {50 kgf/cm ² }	7 MPa {70 kgf/cm ² }
DS11P	5.0	4.5	4.1	3.9	0.15	0.28	0.55	0.82	1.1
DS12P	7.7	7.2	6.7	6.5	0.20	0.40	0.75	1.12	1.5
DS13P	12.6	11.8	11.5	11.0	0.25	0.50	1.05	1.55	2.1
DS14P	22.1	21.2	20.5	20.0	0.35	0.77	1.65	2.50	3.4

Note: Vane pump models

DS1※P-20S5: For VD※-8A1R-30, DS1※P-20S2: For VD※-15A※R-95 or VD※-38A※R-95

Piston Pump Specifications

Relationship between the protruding length of the discharge rate adjusting screw and the discharge rate

● The discharge rate can be roughly judged from the protruding length of the discharge rate adjusting screw (L).

(Note: The discharge rate for VD※-8A1R-30 cannot be adjusted.)

VD※-15A※R-95

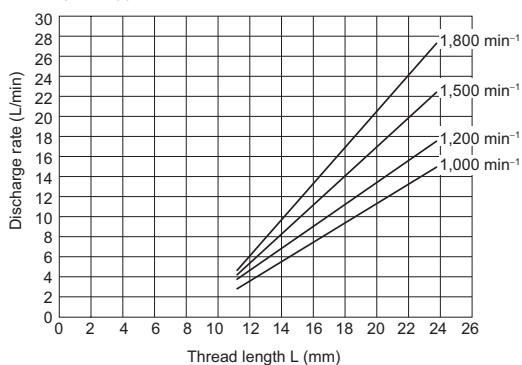

VD※-38A※R-95

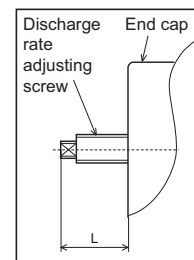
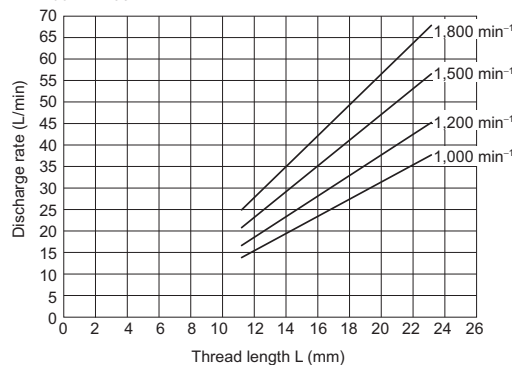

Refer to Page A-8 for other detailed specifications.

V1515 series Dual Pump

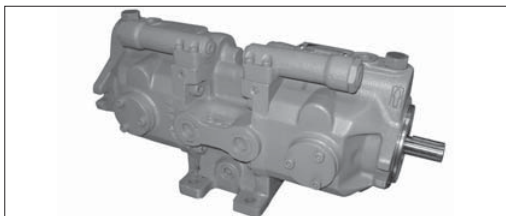

JIS graphic symbols for hydraulic system

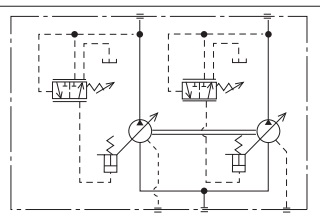

Nomenclature

V1515 A ※ ※ R - 95

1

2

3

4

5

6

1 Model No.

V1515: V1515 series dual pump
 Pump capacity: $14.8 \text{ cm}^3 \times 2$
 Not provided with a discharge rate adjusting screw

2 Control method

A: Pressure compensator control

3 Pump pressure adjustment range at end side

1: 0.8 to 7 MPa { 8 to 70 kgf/cm² }
 2: 1.5 to 14 MPa { 15 to 140 kgf/cm² }

4 Pump pressure adjustment range at shaft side

1: 0.8 to 7 MPa { 8 to 70 kgf/cm² }
 2: 1.5 to 14 MPa { 15 to 140 kgf/cm² }
 3: 3.5 to 21 MPa { 35 to 210 kgf/cm² }

5 Direction of rotation, when viewed from the shaft end

R: Clockwise (rightward)

6 Design No. (The design No. is subject to change)

Note: Risers are not provided with the pump. Order them separately as required by referring to the drawing below.

Forward/backward compatibility of products subject to model changes

● Piston pump (V8A)

Model code of currently used product	Installation compatibility with current design (No. 20)	Notes
V8A1RX-10	Compatible	The external dimensions differ. (See *1)
V8A1RXT-10	Compatible	The external dimensions differ. (See *1)

The compatibility is indicated in the table as follows:

Compatible: Installation compatibility provided (The external dimensions differ.)

V8A1RXT-※※ is dedicated to motor pumps.

Note: T: Tongue shaft

<Time line of design numbers>

Design No. change	Details of change
10 → 20	Pump drain port height: 64 mm → 66 mm, Mass: 7.9 kg → 8.9 kg (See the drawing below) *1

Forward/backward compatibility of products subject to model changes

● Piston pump (V15A)

Model code of currently used product	Installation compatibility with current design (No. 95)	Notes
V15A×R-10	Not compatible	The piping positions (see external dimensions) and connection methods differ. (See *1 and *2.)
V15A×R-40	Partly compatible	The connection methods and external dimensions differ. (See *2 and *3.)
V15A×R-80	Compatible	External dimensions differ. (See *3 and *4.)
V15A×R-85	Compatible	External dimensions differ. (See *4.)
V15A×RX-10	Not compatible	The piping positions (see external dimensions) and connection methods differ. (See *1 and *2.)
V15A×RX-40	Partly compatible	The connection methods and external dimensions differ. (See *2 and *3.)
V15A×RX-80	Compatible	External dimensions differ. (See *3 and *4.)
V15A×RX-85	Compatible	External dimensions differ. (See *4.)
V15A1RY-85	Compatible	External dimensions differ. (See *4.)

The compatibility is indicated in the table as follows:

- Compatible: Installation compatibility provided (The external dimensions differ.)
- Partly compatible: Installation compatibility provided (Some piping needs to be corrected.)
- Not compatible: Installation compatibility not provided

<Time line of design numbers>

Design No. change	Details of change	
10 → 40	Piping positions changed	*1
40 → 80	Piping method changed: bonded seal → O-ring boss	*2
80 → 85	Housing changed (housing communalized by adding V15A1RY)	*3
85 → 95	Bottom part dimension: 60 mm → 66 mm (See the drawing below) Mass: 11.3 kg → 12.5 kg for V15A×R-95, 12.8 kg → 14.5kg for V15A×RX-95, 12.8 kg → 13.5 kg for V15A1RY-95	*4

Forward/backward compatibility of products subject to model changes

● Piston pump (V23A)

Model code of currently used product	Installation compatibility with current design (No. 30)	Notes
V23A×R-10	Not compatible	The piping positions (see external dimensions) and connection methods differ. (See *1.)
V23A×R-20	Partly compatible	The connection methods differ. (See *1.)
V23A×RX-10	Not compatible	The piping positions (see external dimensions) and connection methods differ. (See *1.)
V23A×RX-20	Partly compatible	The connection methods differ. (See *1.)

The compatibility is indicated in the table as follows:
 Partly compatible: Installation compatibility provided (Some piping needs to be corrected.)

<Time line of design numbers>

Design No. change	Details of change	Remarks
10 → 20		
20 → 30	Piping method changed: bonded seal → O-ring boss	*1

● Piston pump (V38A)

Model code of currently used product	Installation compatibility with current design (No. 95)	Notes
V38A×R-10	Not compatible	The piping positions (see external dimensions) and connection methods differ. (See *2 and *3.)
V38A×R-50	Partly compatible	The connection methods and external dimensions differ. (See *3 and *4.)
V38A×R-80	Compatible	External dimensions differ. (See *4.)
V38A×RX-10	Not compatible	The piping positions (see external dimensions) and connection methods differ. (See *2 and *3.)
V38A×RX-50	Partly compatible	The connection methods and external dimensions differ. (See *3 and *4.)
V38A×RX-80	Compatible	External dimensions differ. (See *4.)

The compatibility is indicated in the table as follows:
 Compatible: Installation compatibility provided (The external dimensions differ.)
 Partly compatible: Installation compatibility provided (Some piping needs to be corrected.)
 Not compatible: Installation compatibility not provided

<Time line of design numbers>

Design No. change	Details of change	Remarks
10 → 50	Piping positions changed	*2
50 → 80	Piping method changed: bonded seal → O-ring boss	*3
80 → 95	Bottom part dimension: 75 mm → 79 mm (See the drawing below) Mass: 22 kg → 22.4 kg for V38A×R-95, 23 kg → 26 kg for V38A×RX-95	*4

Forward/backward compatibility of products subject to model changes

● Piston pump (V50A)

Model code of currently used product	Installation compatibility with current design (No. 20)	Notes
V50A×RX-10	Fully compatible	

The compatibility is indicated in the table as follows:

Fully compatible: Installation compatibility provided

● Piston pump (V70A)

Model code of currently used product	Installation compatibility with current design (No. 60)	Notes
V70A×RX-20	Partly compatible	The connection positions of the piping flange differ. (See *1.)
V70A×RX-30	Fully compatible	
V70A×RX-40	Fully compatible	
V70A×RX-50	Fully compatible	

The compatibility is indicated in the table as follows:

Fully compatible: Installation compatibility provided

Partly compatible: Installation compatibility provided (Some piping needs to be corrected.)

<Time line of design numbers>

Design No. change	Details of change	
20 → 30	Flange's width across flats: 204 mm → 208 mm (See the drawing below)	*1
30 → 40		
40 → 50		
50 → 60		

M Series Motor Pumps

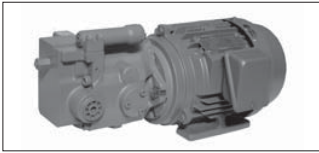

Features

- These are motor pumps that integrate a V series piston pump and an electric motor in one body.

Nomenclature

● Pressure compensator control

※ - M ※ ※ A ※ ※ - ※ ※ - ※ ※ - ※ ※
 1 2 3 4 5 15 17 12 16

● Combination control (pressure feedback method)

※ - M ※ ※ C ※ ※ H X - ※ ※ - ※ ※ - ※ ※
 1 2 3 4 7 8 13 15 17 12 16

● Combination control (solenoid operated method)

※ - M ※ ※ C ※ ※ J ※ X - ※ ※ - ※ ※ - ※ ※
 1 2 3 4 7 8 13 14 15 17 12 16

● Dual pressure control

※ - M ※ ※ D ※ ※ ※ X - ※ ※ - ※ ※ - ※ ※
 1 2 3 4 9 10 14 15 17 12 16

● Power-match control

※ - M ※ ※ SA ※ ※ ※ - ※ ※ - ※ ※
 1 2 3 4 6 11 15 12 16

1 Applicable fluid code (Refer to Page B-1 for the applicable models)

No designation: Petroleum-based hydraulic fluid
 W: Water-glycol hydraulic fluid
 F: Phosphate ester hydraulic fluid

2 Model No.

M: M series motor pump

3 Pump capacity

8: V 8 (8.0 cm³/rev)
 15: V15 (14.8 cm³/rev)
 23: V23 (23.0 cm³/rev)
 38: V38 (37.7 cm³/rev)

4 Control method I (Refer to Page B-1 for the applicable models)

A: Pressure compensator control
 C: Combination control
 D: Dual pressure control
 SA: Power-match control

5 6 Pressure adjustment range (See the pressure adjustment range table)

7 9 Low pressure adjustment range (See the pressure adjustment range table)

8 10 High pressure adjustment range (See the pressure adjustment range table)

11 FC valve differential pressure

A: 0.7 MPa { 7 kgf/cm² }
 B: 1.4 MPa { 14 kgf/cm² }
 C: 2.1 MPa { 21 kgf/cm² }

12 Motor output code (See the motor specification table)

13 Control method II

H: Pressure feedback method
 J: Solenoid operated method

14 Voltage code for the solenoid valve

A: AC 100 V (50/60 Hz), AC 110 V (60 Hz)
 B: AC 200 V (50/60 Hz), AC 220 V (60 Hz)
 N: DC 12 V
 P: DC 24 V

15 Piping direction (Refer to Page B-1 for the applicable models)

No designation: Axial port
 X: Side port

16 Design No. (The design No. is subject to change) *1

50: Pump model M8
 90: Pump model M15
 60: Pump model M23
 70: Pump model M38

17 Control method III (Refer to Page B-1 for the applicable models)

No designation: Without remote control system
 RC: With remote control system

Note: *1 Refer to Pages B-11 to 17 for information on forward/backward compatibility.

Note: JR-G(T)02 and JRP-G02 are recommended for the relief valve of the remote control system. If the vent port is blocked, the pressure compensator does not function and the pump operates at a fixed pressure.

Models and pressure adjustment range table

● **Pressure compensator control (4 = A)**

5 Pressure adjustment range

Code	Pressure adjustment range MPa {kgf/cm ² }	Without remote control system				With remote control system		
		M8	M15	M23	M38	M15	M23	M38
1	0.8 to 7 { 8 to 70}	✓	✓	✓	✓	-	-	-
2	1.5 to 14 {15 to 140}	-	✓	✓	✓	-	-	-
3	1.5 to 21 {15 to 210}	-	-	-	-	✓	-	-
3	3.5 to 21 {35 to 210}	-	✓	✓	✓	-	-	-
4	1.5 to 25 {15 to 250}	-	-	-	-	-	✓	✓
4	3.5 to 25 {35 to 250}	-	-	✓	✓	-	-	-

● **Combination control (4 = C, 13 = H (pressure feedback method) or 13 = J (solenoid operated method))**

7 Low pressure adjustment range

Code	Pressure adjustment range MPa {kgf/cm ² }	Pressure feedback method			Solenoid operated method		
		M15	M23	M38	M15	M23	M38
1	1.5 to 7 {15 to 70}	-	-	-	✓	✓	✓
1	2.5 to 7 {25 to 70}	✓	✓	✓	-	-	-
2	1.5 to 14 {15 to 140}	-	-	-	✓	✓	✓
2	2.5 to 14 {25 to 140}	✓	✓	✓	-	-	-

8 High pressure adjustment range

Code	Pressure adjustment range MPa {kgf/cm ² }	Without remote control system						With remote control system					
		Pressure feedback method			Solenoid operated method			Pressure feedback method			Solenoid operated method		
		M15	M23	M38	M15	M23	M38	M15	M23	M38	M15	M23	M38
1	1.5 to 7 {15 to 70}	-	-	-	✓	✓	✓	-	-	-	-	-	-
1	2.5 to 7 {25 to 70}	✓	✓	✓	-	-	-	-	-	-	-	-	-
2	1.5 to 14 {15 to 140}	-	-	-	✓	✓	✓	-	-	-	-	-	-
2	2.5 to 14 {25 to 140}	✓	✓	✓	-	-	-	-	-	-	-	-	-
3	3.5 to 21 {35 to 210}	✓	✓	✓	✓	✓	✓	✓	-	-	✓	-	-
4	3.5 to 25 {35 to 250}	-	✓	✓	-	✓	✓	-	✓	✓	-	✓	✓

● **Dual pressure control (4 = D)**

9 Low pressure adjustment range

Code	Pressure adjustment range MPa {kgf/cm ² }	M15	M23	M38
1	1.5 to 7 {15 to 70}	✓	✓	✓
2	1.5 to 14 {15 to 140}	✓	✓	✓

Note: If both low and high pressure adjustment ranges are the 1st pattern, the pressure adjustment range becomes 0.8 to 7 MPa {8 to 70 kgf/cm²}.

10 High pressure adjustment range

Code	Pressure adjustment range MPa {kgf/cm ² }	Without remote control system			With remote control system		
		M15	M23	M38	M15	M23	M38
1	1.5 to 7 {15 to 70}	✓	✓	✓	-	-	-
2	1.5 to 14 {15 to 140}	✓	✓	✓	-	-	-
3	3.5 to 21 {35 to 210}	✓	✓	✓	✓	-	-
4	3.5 to 25 {35 to 250}	-	✓	✓	-	✓	✓

● **Power-match control (4 = SA)**

6 Pressure adjustment range

Code	Pressure adjustment range MPa {kgf/cm ² }	M15	M23	M38
1	0.8 to 7 { 8 to 70}	✓	✓	✓
2	1.5 to 14 {15 to 140}	✓	✓	✓
3	3.5 to 21 {35 to 210}	✓	✓	✓

12: Motor output and specifications

Code	Output (kW) (Number of poles: 4P)	Motor rated ampere A			Applicable model			
		200 V (50 Hz)	200 V (60 Hz)	220 V (60 Hz)	M8	M15	M23	M38
05	0.4	2.2	2.0	2.0	✓	-	-	-
1	0.75	3.8	3.4	3.4	✓	✓	-	-
2	1.5	6.8	6.2	6.0	✓	✓	-	-
3	2.2	9.3	8.8	8.3	-	✓	✓	✓
5	3.7	15.0	14.0	13.2	-	✓	✓	✓
7	5.5	22.4	21.0	19.6	-	-	✓	✓
10	7.5	28.8	27.6	25.6	-	-	-	✓

Motor output characteristics selection curves

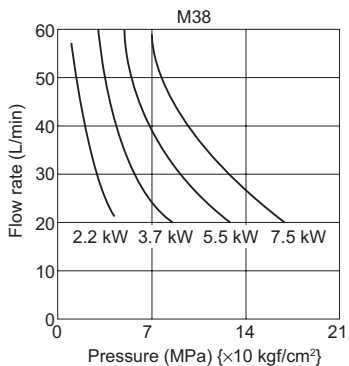
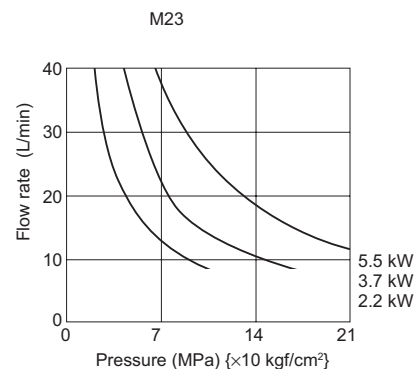
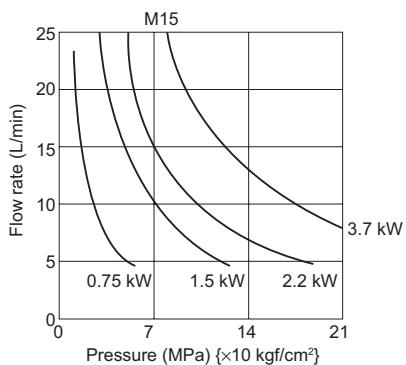
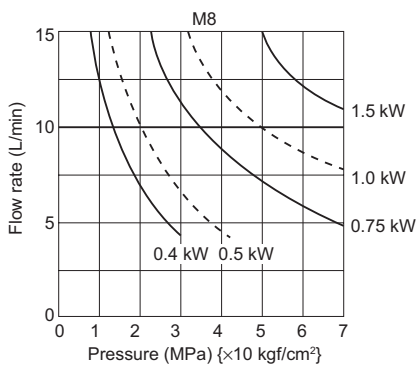

Compatibility of products subject to model changes

B

MOTOR PUMPS

● Motor pump (M8A1X)

Model code of currently used product	Installation compatibility with current design (No. 50)	Model code of pump equipped	Procurement code when replacing the pump alone	Procurement code when replacing the motor alone	Notes
M8A1X-05-10	Compatible	V8A1RXT-10	V8A1RXT-20	-	*1
M8A1X-05-20	Compatible	V8A1RX-10	V8A1RX-20	SP1967-041RE	
M8A1X-05-40	Compatible	V8A1RX-20			
M8A1X-1-10	Compatible	V8A1RXT-10	V8A1RXT-20	-	*1
M8A1X-1-20	Compatible	V8A1RX-10	V8A1RX-20	SP1967-071RE	
M8A1X-1-30	Compatible				
M8A1X-1-35	Compatible	V8A1RX-20			
M8A1X-1-40	Compatible				
M8A1X-2-10	Compatible	V8A1RXT-10	V8A1RXT-20	-	*1
M8A1X-2-20	Compatible	V8A1RX-10	V8A1RX-20	SP1967-151RE	
M8A1X-2-40	Compatible	V8A1RX-20			

The compatibility is indicated in the table as follows:

Compatible: Installation compatibility provided (The external dimensions differ.)

Note: *1 Design No. 10 uses a tongue shaft pump and, accordingly, a tongue shaft type motor is used. Since the motor is not compatible with the motor (key shaft type) used in the current design, it is not possible to replace the motor alone. When replacing the pump alone, use V8A1RXT-20.

Note: The motor and pump are directly coupled. If it is difficult to decouple them, replace them as a set.

<Time line of design numbers>

(✓: Models with actual production history)

Design No.	M8A1X-05	M8A1X-1	M8A1X-2	Details of changes from the previous design
10	✓	✓	✓	
20	✓	✓	✓	Pump changed (from tongue shaft to key shaft), motor changed (to key shaft type)
30	-	✓	-	Motor changed (installation compatibility provided)
35	-	✓	-	Pump design changed: 10 → 20
40	✓	✓	✓	M8A1X-05, -2: Pump design changed: 10 → 20
				M8A1X-1: Motor changed (installation compatibility provided)
50	✓	✓	✓	Motor changed (installation compatibility provided)

Refer to Page A-68 for the time line of pump design numbers.

Compatibility of products subject to model changes

● Motor pump (M15A※)

Model code of currently used product	Installation compatibility with current design (No. 90)	Design number of pump equipped	Procurement code when replacing the pump alone	Procurement code when replacing the motor alone	Notes
M15A※-1-20	Not compatible	10	V15A※R-95	SP1968-071RE	*1
M15A※-1-30	Partly compatible	40			
M15A※-1-40	Compatible	80			
M15A※-1-45	Compatible	85			
M15A※-1-50	Compatible				
M15A※-1-60	Compatible	95			
M15A※-2-20	Not compatible	10	V15A※R-95	SP1968-151RE	*1
M15A※-2-30	Partly compatible	40			
M15A※-2-40	Compatible	80			
M15A※-2-45	Compatible	85			
M15A※-2-50	Compatible				
M15A※-2-60	Compatible	95			
M15A※-2-65	Compatible	85			
M15A※-2-70	Compatible	95			
M15A※-3-20	Not compatible	10	V15A※R-95	SP1968-221RE	*1
M15A※-3-30	Partly compatible	40			
M15A※-3-40	Compatible	80			
M15A※-3-45	Compatible	85			
M15A※-3-50	Compatible				
M15A※-3-60	Compatible	95			
M15A※-5-20	Not compatible	10	V15A※R-95	SP1968-371RE	*1
M15A※-5-30	Partly compatible	40			
M15A※-5-40	Compatible	80			
M15A※-5-45	Compatible	85			
M15A※-5-50	Compatible				
M15A※-5-60	Compatible	95			
M15A※-5-80	Compatible				

The compatibility is indicated in the table as follows:

Compatible: Installation compatibility provided (The external dimensions differ.)

Partly compatible: Installation compatibility provided (Some piping needs to be corrected.)

Not compatible: Installation compatibility not provided

Note: *1 Pump designs prior to design No. 40 use different sealing methods to the current design and therefore the piping needs to be changed.

Previous: Bonded seal → Current: O-ring boss

Note: The motor and pump are directly coupled. If it is difficult to decouple them, replace them as a set.

<Time line of design numbers>

(✓: Models with actual production history)

Design No.	M15A※-1	M15A※-2	M15A※-3	M15A※-5	Details of changes from the previous design
20	✓	✓	✓	✓	
30	✓	✓	✓	✓	Pump design changed: 10 → 40, motor changed
40	✓	✓	✓	✓	Pump design changed: 40 → 80, motor changed (installation compatibility provided)
45	✓	✓	✓	✓	Pump design changed: 80 → 85
50	✓	✓	✓	✓	Motor changed (installation compatibility provided)
60	✓	✓	✓	✓	Pump design changed: 85 → 95
65	—	✓	—	—	Motor changed (installation compatibility provided), pump design No. 85 adopted
70	—	✓	—	—	Pump design changed: 85 → 95, motor changed (installation compatibility provided)
80	—	—	—	✓	Motor changed (installation compatibility provided)
90	✓	✓	✓	✓	Motor changed (installation compatibility provided)

Refer to Page A-69 for the time line of pump design numbers.

Compatibility of products subject to model changes

B

MOTOR PUMPS

● Motor pump (M15A×X)

Model code of currently used product	Installation compatibility with current design (No. 90)	Design number of pump equipped	Procurement code when replacing the pump alone	Procurement code when replacing the motor alone	Notes
M15A×X-1-20	Not compatible	10	V15A×RX-95	SP1968-071RE	*1
M15A×X-1-30	Partly compatible	40			
M15A×X-1-40	Compatible	80			
M15A×X-1-45	Compatible	85			
M15A×X-1-50	Compatible				
M15A×X-1-60	Compatible	95			
M15A×X-2-20	Not compatible	10	V15A×RX-95	SP1968-151RE	*1
M15A×X-2-30	Partly compatible	40			
M15A×X-2-40	Compatible	80			
M15A×X-2-45	Compatible	85			
M15A×X-2-50	Compatible				
M15A×X-2-60	Compatible	95			
M15A×X-2-65	Compatible	85			
M15A×X-2-70	Compatible	95			
M15A×X-3-20	Not compatible	10	V15A×RX-95	SP1968-221RE	*1
M15A×X-3-30	Partly compatible	40			
M15A×X-3-40	Compatible	80			
M15A×X-3-45	Compatible	85			
M15A×X-3-50	Compatible				
M15A×X-3-60	Compatible	95			
M15A×X-5-20	Not compatible	10	V15A×RX-95	SP1968-371RE	*1
M15A×X-5-30	Partly compatible	40			
M15A×X-5-40	Compatible	80			
M15A×X-5-45	Compatible	85			
M15A×X-5-50	Compatible				
M15A×X-5-60	Compatible	95			
M15A×X-5-80	Compatible				

The compatibility is indicated in the table as follows:

Compatible: Installation compatibility provided (The external dimensions differ.)

Partly compatible: Installation compatibility provided (Some piping needs to be corrected.)

Not compatible: Installation compatibility not provided

Note: *1 Pump designs prior to design No. 40 use different sealing methods to the current design and therefore the piping needs to be changed.

Previous: Bonded seal → Current: O-ring

Note: The motor and pump are directly coupled. If it is difficult to decouple them, replace them as a set.

<Time line of design numbers>

(✓: Models with actual production history)

Design No.	M15A×X-1	M15A×X-2	M15A×X-3	M15A×X-5	Details of changes from the previous design
20	✓	✓	✓	✓	
30	✓	✓	✓	✓	Pump design changed: 10 → 40, motor changed
40	✓	✓	✓	✓	Pump design changed: 40 → 80, motor changed (installation compatibility provided)
45	✓	✓	✓	✓	Pump design changed: 80 → 85
50	✓	✓	✓	✓	Motor changed (installation compatibility provided)
60	✓	✓	✓	✓	Pump design changed: 85 → 95
65	—	✓	—	—	Motor changed (installation compatibility provided), pump design No. 85 adopted
70	—	✓	—	—	Pump design changed: 85 → 95, motor changed (installation compatibility provided)
80	—	—	—	✓	Motor changed (installation compatibility provided)
90	✓	✓	✓	✓	Motor changed (installation compatibility provided)

Refer to Page A-69 for the time line of pump design numbers.

Compatibility of products subject to model changes

● Motor pump (M15A1Y)

Model code of currently used product	Installation compatibility with current design (No. 90)	Design number of pump equipped	Procurement code when replacing the pump alone	Procurement code when replacing the motor alone	Notes
M15A1Y-1-45	Compatible	85	V15A1RY-95	SP1968-071RE	
M15A1Y-1-50	Compatible				
M15A1Y-1-60	Compatible	95			
M15A1Y-2-45	Compatible	85	V15A1RY-95	SP1968-151RE	
M15A1Y-2-50	Compatible				
M15A1Y-2-60	Compatible	95			
M15A1Y-2-65	Compatible	85			
M15A1Y-2-70	Compatible	95			
M15A1Y-3-45	Compatible	85	V15A1RY-95	SP1968-221RE	
M15A1Y-3-50	Compatible				
M15A1Y-3-60	Compatible	95			
M15A1Y-5-45	Compatible	85	V15A1RY-95	SP1968-371RE	
M15A1Y-5-50	Compatible				
M15A1Y-5-60	Compatible	95			
M15A1Y-5-80	Compatible				

The compatibility is indicated in the table as follows:

Compatible: Installation compatibility provided (The external dimensions differ.)

Note: The motor and pump are directly coupled. If it is difficult to decouple them, replace them as a set.

<Time line of design numbers>

(✓: Models with actual production history)

Design No.	M15A×Y-1	M15A×Y-2	M15A×Y-3	M15A×Y-5	Details of changes from the previous design
45	✓	✓	✓	✓	
50	✓	✓	✓	✓	Motor changed (installation compatibility provided)
60	✓	✓	✓	✓	Pump design changed: 85 → 95
65	–	✓	–	–	Motor changed (installation compatibility provided), pump design No. 85 adopted
70	–	✓	–	–	Pump design changed: 85 → 95, motor changed (installation compatibility provided)
80	–	–	–	✓	Motor changed (installation compatibility provided)
90	✓	✓	✓	✓	Motor changed (installation compatibility provided)

Refer to Page A-69 for the time line of pump design numbers.

Compatibility of products subject to model changes

● Motor pump (M23A※)

Model code of currently used product	Installation compatibility with current design (No. 60)	Design number of pump equipped	Procurement code when replacing the pump alone	Procurement code when replacing the motor alone	Notes
M23A※-3-30	Partly compatible	20	V23A※R-30	SP1975-221RE	*1
M23A※-3-40	Compatible	30			
M23A※-3-50	Compatible				
M23A※-5-30	Partly compatible	20	V23A※R-30	SP1975-371RE	*1
M23A※-5-40	Compatible	30			
M23A※-5-50	Compatible				
M23A※-7-30	Partly compatible	20	V23A※R-30	SP1975-551RE	*1
M23A※-7-40	Compatible	30			
Model code of currently used product	Installation compatibility with current design (No. 60)	Design number of pump equipped	Procurement code when replacing the pump alone	Procurement code when replacing the motor alone	Notes
M23A※X-3-30	Partly compatible	20	V23A※RX-30	SP1975-221RE	*1
M23A※X-3-40	Compatible	30			
M23A※X-3-50	Compatible				
M23A※X-5-30	Partly compatible	20	V23A※RX-30	SP1975-371RE	*1
M23A※X-5-40	Compatible	30			
M23A※X-5-50	Compatible				
M23A※X-7-30	Partly compatible	20	V23A※RX-30	SP1975-551RE	*1
M23A※X-7-40	Compatible	30			

The compatibility is indicated in the table as follows:

Compatible: Installation compatibility provided (The external dimensions differ.)

Partly compatible: Installation compatibility provided (Some piping needs to be corrected.)

Note: *1 Pump designs prior to design No. 20 use different sealing methods to the current design and therefore the piping needs to be changed.

Previous: Bonded seal → Current: O-ring boss

<Time line of design numbers>

(✓: Models with actual production history)

Design No.	M23A※-3	M23A※-5	M23A※-7	Details of changes from the previous design
30	✓	✓	✓	
40	✓	✓	✓	Pump design changed: 20 → 30
50	✓	✓	—	Motor changed (installation compatibility provided)
60	✓	✓	✓	Motor changed (installation compatibility provided)

(✓: Models with actual production history)

Design No.	M23A※X-3	M23A※X-5	M23A※X-7	Details of changes from the previous design
30	✓	✓	✓	
40	✓	✓	✓	Pump design changed: 20 → 30
50	✓	✓	—	Motor changed (installation compatibility provided)
60	✓	✓	✓	Motor changed (installation compatibility provided)

Refer to Page A-70 for the time line of pump design numbers.

Compatibility of products subject to model changes

● Motor pump (M38A)

Model code of currently used product	Installation compatibility with current design (No. 70)	Design number of pump equipped	Procurement code when replacing the pump alone	Procurement code when replacing the motor alone	Notes
M38A×-3-20	Not compatible	10	V38A×R-95	SP1975-221RE	
M38A×-3-30	Partly compatible	50			*1
M38A×-3-31	Partly compatible				*1
M38A×-3-40	Compatible	80			
M38A×-3-50	Compatible	95			
M38A×-3-60	Compatible				
M38A×-5-20	Not compatible	10	V38A×R-95	SP1975-371RE	
M38A×-5-30	Partly compatible	50			*1
M38A×-5-31	Partly compatible				*1
M38A×-5-40	Compatible	80			
M38A×-5-50	Compatible	95			
M38A×-5-60	Compatible				
M38A×-7-20	Not compatible	10	V38A×R-95	SP1975-551RE	
M38A×-7-31	Partly compatible	50			*1
M38A×-7-40	Compatible	80			
M38A×-7-50	Compatible	95			
M38A×-10-40	Compatible	80	V38A×R-95	SP1975-751RE	
M38A×-10-50	Compatible	95			

The compatibility is indicated in the table as follows:

Compatible: Installation compatibility provided (The external dimensions differ.)

Partly compatible: Installation compatibility provided (Some piping needs to be corrected.)

Not compatible: Installation compatibility not provided

Note: *1 Pump designs prior to design No. 50 use different sealing methods to the current design and therefore the piping needs to be changed.

Previous: Bonded seal → Current: O-ring boss

<Time line of design numbers>

(✓: Models with actual production history)

Design No.	M38A×-3	M38A×-5	M38A×-7	M38A×-10	Details of changes from the previous design
20	✓	✓	✓	✓	
30	✓	✓	✓	✓	Pump design changed: 10 → 50
31	✓	✓	✓	✓	Motor changed (installation compatibility provided)
40	✓	✓	✓	✓	Pump design changed: 50 → 80
50	✓	✓	✓	✓	Pump design changed: 80 → 95
60	✓	✓	—	—	Motor changed (installation compatibility provided)
70	✓	✓	✓	✓	Motor changed (installation compatibility provided)

Refer to Page A-70 for the time line of pump design numbers.

Compatibility of products subject to model changes

● Motor pump (M38A※X)

Model code of currently used product	Installation compatibility with current design (No. 70)	Design number of pump equipped	Procurement code when replacing the pump alone	Procurement code when replacing the motor alone	Notes
M38A※X-3-20	Not compatible	10	V38A※RX-95	SP1975-221RE	
M38A※X-3-30	Partly compatible	50			*1
M38A※X-3-31	Partly compatible				
M38A※X-3-40	Compatible	80			
M38A※X-3-50	Compatible	95			
M38A※X-3-60	Compatible				
M38A※X-5-20	Not compatible	10	V38A※RX-95	SP1975-371RE	
M38A※X-5-30	Partly compatible	50			*1
M38A※X-5-31	Partly compatible				
M38A※X-5-40	Compatible	80			
M38A※X-5-50	Compatible	95			
M38A※X-5-60	Compatible				
M38A※X-7-20	Not compatible	10	V38A※RX-95	SP1975-551RE	
M38A※X-7-31	Partly compatible	50			*1
M38A※X-7-40	Compatible	80			
M38A※X-7-50	Compatible	95			
M38A※X-10-40	Compatible	80	V38A※RX-95	SP1975-751RE	
M38A※X-10-50	Compatible	95			

The compatibility is indicated in the table as follows:

Compatible: Installation compatibility provided (The external dimensions differ.)

Partly compatible: Installation compatibility provided (Some piping needs to be corrected.)

Not compatible: Installation compatibility not provided

Note: *1 Pump designs prior to design No. 50 use different sealing methods to the current design and therefore the piping needs to be changed.

Previous: Bonded seal → Current: O-ring boss

<Time line of design numbers>

(✓: Models with actual production history)

Design No.	M38A※X-3	M38A※X-5	M38A※X-7	M38A※X-10	Details of changes from the previous design
20	✓	✓	✓	✓	
30	✓	✓	✓	✓	Pump design changed: 10 → 50
31	✓	✓	✓	✓	Motor changed (installation compatibility provided)
40	✓	✓	✓	✓	Pump design changed: 50 → 80
50	✓	✓	✓	✓	Pump design changed: 80 → 95
60	✓	✓	—	—	Motor changed (installation compatibility provided)
70	✓	✓	✓	✓	Motor changed (installation compatibility provided)

Refer to Page A-70 for the time line of pump design numbers.

DAIKIN INDUSTRIES, LTD.

Oil Hydraulic Equipment

Osaka Office

YODOGAWA PLANT

1-1, Nishi-Hitotsuya, Settsu, Osaka 566-8585, Japan

Indian Representative

Technocrats Alliance Engineering Pvt. Ltd.

Works/Correspondence Office : 11/23, TIL Compound, Site-IV,
Sahibabad Industrial Area, Ghaziabad - 201010 (UP) INDIA

Registered Office : C - 12 / 333, Yamuna Vihar, Delhi - 110053 INDIA

Tel: +91-11- 42448311, 22448312 Fax: +91-11-4248312

E-mail : info@tca.co.in website : www.tca.co.in